

CALWA RECREATION & PARK DISTRICT MEETING AGENDA

www.calwarecreation.org

BOARD MEETING MINUTES

August 20, 2019

Regular Session 6:30 P.M.

CALWA PARK HALL– 4545 E. CHURCH AVE., FRESNO, CALIFORNIA

BOARD CHAIRPERSON

Raul Guerra, Chair

DISTRICT ADMINISTRATOR

Felix Ortiz

BOARD VICE CHAIR

Mary L. Rosales Vice Chair

DISTRICT COUNSEL

Hilda Cantú Montoy

BOARD MEMBERS

Jose Luis Sanchez, Board Member

Gabriela Mares, Board Member

Esmeralda Zamora, Board Member

The Calwa Recreation and Park District Board of Directors welcomes you to its meetings and encourages you to participate. This agenda contains a brief general description of each item that will be considered by the Board. All attendees are advised that pagers, cell phones, and any other communication devices should be powered off upon entering the Board meeting.

The Board may consider and act on an agenda item in any order it deems appropriate. Actual timed items may be heard later but not before the time set on agenda. Persons interested in an item listed on the agenda are advised to be present throughout the meeting to ensure their presence when the item is called.

A. Call to Order and Roll Call

Meeting was called to order by Board Vice Chair Mary L. Rosales at 6:30 p.m. Roll call: Board Chairperson Raul Guerra was absent; Board Vice Chair Mary L. Rosales was present; Board Member Jose Luis Sanchez was present; Board Member Gabriela Mares was present; Board Member Esmeralda Zamora was present.

B. Invocation and Flag Salute

Invocation and Flag Salute were led by Board Vice Chair Mary L. Rosales.

C. Approval of Agenda

Steve Rapada from Sal Quientero's office came to present along with Ari Martinez, Lou Brossi and Mike Kludjian on the swimming pool project. A meeting was held to bring the total cost of the swimming pool down so that it could be kept in same location as it is in now, but the deep end will be now filled in with dirt. Pool equipment room will be relocated and original will be turned into storage. Bathrooms and showers will be renovated by Mark with the CMG company. Outside showers were approved by environmental health department. New swimming pool size is going to be 44' x 88'. The shallow end of the swimming pool will be rebuilt. Kaiser Permanente has extended their grant deadline until May of 2020 and was willing to work with us on a month to month basis extension if needed. Steve Rapada stated that they had a total of \$191,000 cash from sponsor's or committed donations. JD Foods are talking to Steve Rapada about donating to help cover the cost of maintenance for the swimming pool once it was built. \$285,000 is the commitment from Fresno County towards to the swimming pool project and that it won't cost Calwa Park anything. Approval of resolution passed with corrections to swimming pool project. Motion made by Board Member Jose Luis Sanchez and Seconded by Board Member Gabriela Mares. 4-0 approved and 0-opposed.

H. CLOSED SESSION

None

I. DISTRICT ADMINISTRATOR REPORT

1. We have started up a After School tutoring program that is free Monday, Tuesday, Thursday and Fridays. 2:00 p.m. to 6:00 p.m. except on Wednesday's from 2:00 p.m. to 5:00 p.m.
2. We have been taking Flag Football Registrations.
3. We are looking to amending the facility rental fees.
4. Goal posts will be painted soon; new nets have been bought and we also have the barrier net to put up.
5. We had a great turn out this past Saturday for the soccer banquet.
6. Amigo's Food Market sponsored 3 teams for flag football.
7. Swimming pool project donations:
 - *City of Fresno \$5,000
 - *Mid Valley Distributors \$500.
 - *American Ambulance \$5,000

New Total for Swimming Pool Project is \$126,500.

J. REPORT OF FINAL ACTIONS TAKEN IN CLOSED SESSION, IF ANY

K. ADJOURNMENT

Meeting was adjourned at 7:22 p.m.

	Jul-19	Aug-19	Sep-19	Oct-19	Nov-19	Dec-19	Jan-20	Feb-20	Mar-19	Apr-19	May-19	Jun-20	YTD TOTAL	Dollar	Percentage Left	
Employee Cost																
Employee Salaries	\$ 17,647.00	\$ 15,547.00	\$ 15,547.00	\$ 22,878.00	\$ 15,547.00	\$ 15,547.00	\$ 15,547.00	\$ 15,547.00	\$ 22,878.00	\$ 15,547.00	\$ 15,547.00	\$ 19,102.00	\$ 208,882.00	\$ 180,062.18	86.20%	
Overtime	\$ 75.00	\$ 75.00	\$ 75.00	\$ 75.00	\$ 75.00	\$ 75.00	\$ 75.00	\$ 75.00	\$ 200.00	\$ 200.00	\$ 200.00	\$ 200.00	\$ 1,525.00	\$ 1,525.00		
Payroll Taxes	\$ 1,392.00	\$ 1,392.00	\$ 1,392.00	\$ 2,169.00	\$ 1,392.00	\$ 1,392.00	\$ 1,392.00	\$ 1,392.00	\$ 2,169.00	\$ 1,392.00	\$ 1,392.00	\$ 1,392.00	\$ 18,258.00	\$ 16,094.01	88.15%	
Payroll Fees	\$ 869.62	\$ 208.00	\$ 208.00	\$ 208.00	\$ 208.00	\$ 208.00	\$ 208.00	\$ 208.00	\$ 208.00	\$ 208.00	\$ 208.00	\$ 208.00	\$ 2,496.00	\$ 2,135.50	85.56%	
Director Stipends	\$ 1,405.77	\$ 219.93	\$ 500.00	\$ 500.00	\$ 500.00	\$ 500.00	\$ 500.00	\$ 500.00	\$ 500.00	\$ 500.00	\$ 500.00	\$ 1,000.00	\$ 7,500.00	\$ 7,500.00	100.00%	
Workers Compensation	\$ 8,000.00	\$ -	\$ -	\$ -	\$ -	\$ -	\$ -	\$ -	\$ -	\$ -	\$ -	\$ -	\$ 8,000.00	\$ 8,000.00	100.00%	
HR miscellaneous	\$ 144.00	\$ 144.00	\$ 144.00	\$ 144.00	\$ 144.00	\$ 144.00	\$ 144.00	\$ 144.00	\$ 144.00	\$ 144.00	\$ 144.00	\$ 144.00	\$ 1,728.00	\$ 1,402.91	81.19%	
Total	\$ 28,466.00	\$ 18,366.00	\$ 18,866.00	\$ 25,874.00	\$ 17,866.00	\$ 17,866.00	\$ 17,866.00	\$ 17,866.00	\$ 26,100.00	\$ 18,891.00	\$ 18,891.00	\$ 22,846.00	\$ 248,389.00	\$ 216,719.60	87.25%	
	\$ 15,594.16	\$ 16,075.24	\$ -	\$ -	\$ -	\$ -	\$ -	\$ -	\$ -	\$ -	\$ -	\$ -	\$ 31,669.40	\$ -		
Expenses																
Audit	\$ -	\$ -	\$ -	\$ -	\$ -	\$ -	\$ 8,000.00	\$ -	\$ -	\$ -	\$ -	\$ -	\$ -	\$ 8,000.00	\$ 8,000.00	100.00%
Bank Fees	\$ 23.00	\$ 22.00	\$ 22.00	\$ 22.00	\$ 22.00	\$ 22.00	\$ 22.00	\$ 22.00	\$ 22.00	\$ 22.00	\$ 22.00	\$ 22.00	\$ 264.00	\$ 264.00	100.00%	
Cleaning Supplies	\$ 1,200.00	\$ 500.00	\$ 500.00	\$ 400.00	\$ 500.00	\$ 300.00	\$ 350.00	\$ 500.00	\$ 800.00	\$ 350.00	\$ 500.00	\$ 500.00	\$ 6,400.00	\$ 5,332.02	83.31%	
District Counsel	\$ 1,000.00	\$ 1,000.00	\$ 1,000.00	\$ 1,000.00	\$ 1,000.00	\$ 1,000.00	\$ 1,000.00	\$ 1,000.00	\$ 1,000.00	\$ 1,000.00	\$ 1,000.00	\$ 1,000.00	\$ 12,000.00	\$ 11,070.00	92.25%	
District Board Elections	\$ -	\$ 3,000.00	\$ -	\$ -	\$ -	\$ -	\$ -	\$ -	\$ -	\$ -	\$ -	\$ -	\$ 3,000.00	\$ 3,000.00	100.00%	
Electricity	\$ 3,050.00	\$ 2,650.00	\$ 3,750.00	\$ 2,750.00	\$ 2,610.00	\$ 3,050.00	\$ 2,750.00	\$ 3,150.00	\$ 2,800.00	\$ 3,650.00	\$ 3,150.00	\$ 2,488.00	\$ 36,198.00	\$ 29,868.57	82.51%	
Equipment Fuel	\$ 114.00	\$ 150.00	\$ 140.00	\$ 118.00	\$ 125.00	\$ 65.00	\$ 180.00	\$ 150.00	\$ 130.00	\$ 118.00	\$ 97.00	\$ 118.00	\$ 1,505.00	\$ 1,172.64	77.92%	
Event Costs	\$ 68.36	\$ 264.00	\$ 225.00	\$ 225.00	\$ 225.00	\$ 225.00	\$ 225.00	\$ 225.00	\$ 225.00	\$ 225.00	\$ 225.00	\$ 225.00	\$ 2,700.00	\$ 2,700.00	100.00%	
Fresno Co Service Fees	\$ -	\$ -	\$ -	\$ -	\$ -	\$ -	\$ -	\$ -	\$ -	\$ -	\$ -	\$ 750.00	\$ 750.00	\$ 750.00	100.00%	
Liability Insurance	\$ 5,000.00	\$ -	\$ -	\$ -	\$ -	\$ -	\$ 5,000.00	\$ -	\$ -	\$ -	\$ -	\$ -	\$ 10,000.00	\$ 10,000.00	100.00%	
Internet	\$ 180.00	\$ 170.00	\$ 210.00	\$ 166.00	\$ 210.00	\$ 210.00	\$ 200.00	\$ 166.00	\$ 210.00	\$ 210.00	\$ 170.00	\$ 20.00	\$ 2,383.00	\$ 1,823.03	79.16%	
Landline Phone	\$ 319.98	\$ 159.99	\$ 120.00	\$ 120.00	\$ 160.00	\$ 160.00	\$ 130.00	\$ 120.00	\$ 160.00	\$ 250.00	\$ 160.00	\$ 210.00	\$ 1,470.00	\$ 1,552.95	83.05%	
Mobile Phone	\$ 120.00	\$ 120.00	\$ 120.00	\$ 120.00	\$ 120.00	\$ 120.00	\$ 120.00	\$ 120.00	\$ 120.00	\$ 120.00	\$ 120.00	\$ 120.00	\$ 1,440.00	\$ 1,248.56	86.71%	
Memberships	\$ 93.01	\$ 98.43	\$ -	\$ -	\$ -	\$ -	\$ -	\$ -	\$ -	\$ -	\$ -	\$ -	\$ 1,920.00	\$ 1,920.00	100.00%	
Mileage	\$ 100.00	\$ -	\$ -	\$ -	\$ -	\$ -	\$ -	\$ -	\$ -	\$ -	\$ -	\$ -	\$ 100.00	\$ 100.00	100.00%	
Office Equipment	\$ 210.00	\$ 170.00	\$ 170.00	\$ 100.00	\$ 180.00	\$ 175.00	\$ 170.00	\$ 200.00	\$ 275.00	\$ 150.00	\$ 150.00	\$ 150.00	\$ 2,100.00	\$ 1,833.99	87.33%	
Office Supplies	\$ 85.00	\$ 100.00	\$ 50.00	\$ 170.00	\$ 180.00	\$ 296.00	\$ 70.00	\$ 50.00	\$ 270.00	\$ 131.00	\$ 85.00	\$ 85.00	\$ 1,972.00	\$ 1,419.84	71.97%	
Professional Development	\$ 227.90	\$ 924.26	\$ -	\$ -	\$ 1,000.00	\$ -	\$ -	\$ -	\$ -	\$ -	\$ -	\$ -	\$ 1,152.16	\$ 1,000.00	100.00%	
Recreation programs	\$ 600.00	\$ 500.00	\$ 400.00	\$ 400.00	\$ 400.00	\$ 300.00	\$ 300.00	\$ 300.00	\$ 308.00	\$ 450.00	\$ 450.00	\$ 450.00	\$ 4,888.00	\$ 4,641.53	95.54%	
Repairs and Maintenance	\$ 408.56	\$ (192.09)	\$ 8,000.00	\$ 4,800.00	\$ 5,000.00	\$ 5,000.00	\$ 5,000.00	\$ 5,000.00	\$ 3,500.00	\$ 3,500.00	\$ 3,500.00	\$ 2,500.00	\$ 52,300.00	\$ 52,300.00	100.00%	
Security	\$ 9,006.51	\$ 3,354.68	\$ 500.00	\$ -	\$ -	\$ 500.00	\$ -	\$ -	\$ 350.00	\$ 500.00	\$ 500.00	\$ 500.00	\$ 2,350.00	\$ 1,864.00	79.32%	
Security Monitoring System	\$ 486.00	\$ -	\$ -	\$ -	\$ -	\$ -	\$ -	\$ -	\$ -	\$ -	\$ -	\$ -	\$ 486.00	\$ 486.00	100.00%	
Technology Services	\$ 10.00	\$ 10.00	\$ 10.00	\$ 10.00	\$ 10.00	\$ 10.00	\$ 10.00	\$ 10.00	\$ 10.00	\$ 10.00	\$ 10.00	\$ 10.00	\$ 60.00	\$ 60.00	100.00%	
Trash Disposal	\$ 150.00	\$ 250.00	\$ 250.00	\$ 250.00	\$ 250.00	\$ 250.00	\$ 250.00	\$ 250.00	\$ 250.00	\$ 250.00	\$ 250.00	\$ 250.00	\$ 3,000.00	\$ 2,518.13	84%	
Vehicle Leasing/Financing	\$ 239.14	\$ 242.73	\$ 375.00	\$ 375.00	\$ 375.00	\$ 375.00	\$ 375.00	\$ 375.00	\$ 375.00	\$ 375.00	\$ 375.00	\$ 375.00	\$ 4,500.00	\$ 21,255.28	472%	
Water	\$ 2,969.98	\$ 5,279.25	\$ 1,500.00	\$ 3,800.00	\$ 2,850.00	\$ 2,000.00	\$ 2,000.00	\$ 1,500.00	\$ 2,500.00	\$ 2,500.00	\$ 2,500.00	\$ 2,500.00	\$ 35,000.00	\$ 26,871.27	76.78%	
Swimming pool maintenance	\$ -	\$ -	\$ -	\$ -	\$ -	\$ -	\$ -	\$ -	\$ -	\$ -	\$ -	\$ -	\$ 3,000.00	\$ 3,000.00	100.00%	
Swimming pool construction	\$ -	\$ -	\$ -	\$ -	\$ -	\$ -	\$ -	\$ -	\$ -	\$ -	\$ -	\$ -	\$ 250,000.00	\$ 35,000.00	100.00%	
Total	\$ 18,251.00	\$ 16,812.00	\$ 101,032.00	\$ 15,746.00	\$ 16,287.00	\$ 68,828.00	\$ 26,792.00	\$ 13,978.00	\$ 63,905.00	\$ 13,901.00	\$ 12,864.00	\$ 84,544.00	\$ 449,520.00	\$ 433,764.62	96%	
	\$ 17,900.78	\$ (1,745.40)	\$ -	\$ -	\$ -	\$ -	\$ -	\$ -	\$ -	\$ -	\$ -	\$ -	\$ 16,155.38	\$ -		
	\$ 46,717.00	\$ 35,176.00	\$ 119,986.00	\$ 41,740.00	\$ 34,153.00	\$ 29,625.00	\$ 44,618.00	\$ 31,989.00	\$ 81,986.00	\$ 40,000.00	\$ 36,855.00	\$ 106,590.00	\$ 696,309.00	\$ 650,484.22	93%	
Grand Total	\$ 33,494.94	\$ 14,529.84	\$ -	\$ -	\$ -	\$ -	\$ -	\$ -	\$ -	\$ -	\$ -	\$ -	\$ 47,824.78	\$ -		

	Aug 19	Budget	Over Budget
Ordinary Income/Expense			
Income			
Park Income (Income recieved from Park Rentals)			
Donation	0.00	0.00	0.00
Events	0.00	2,450.00	-2,450.00
Field Rentals	0.00	150.00	-150.00
Hall Rentals	355.00	100.00	255.00
Miscellaneous	0.00	1,450.00	-1,450.00
Picnic Rental	635.00	100.00	535.00
Rent Payments	1,500.00	1,400.00	100.00
Zumba	1,000.00	600.00	400.00
Total Park Income (Income recieved from Park Rentals)	3,490.00	6,250.00	-2,760.00
The County of Fresno			
2230-unassigned funds	0.00	0.00	0.00
3005-RDA ABX1 26 Property Tax	0.00	0.00	0.00
3006-Redev Tax Increm Reimb	0.00	0.00	0.00
3008-Suppl-Prior Secured	0.00	0.00	0.00
3009-suppl-Current Unsecured	0.00	0.00	0.00
3010-Property Taxes	0.00	0.00	2,300.60
3011-Suppl-Current Secured	2,300.60	0.00	0.00
3015-Property Taxes-current Uns	0.00	0.00	0.00
3025-Property Taxes-Prior Unsec	0.00	0.00	0.00
3030-Penalties & Costs	0.00	0.00	0.00
3380-Interest	0.00	0.00	0.00
3565-State-l/L Homeowners Prop	0.00	0.00	0.00
4369- Federal In lieu housing	0.00	0.00	0.00
5804-ABX126 Other Revenue	0.00	0.00	0.00
The County of Fresno - Other	0.00	28,025.00	-28,025.00
Total The County of Fresno	2,300.60	28,025.00	-25,724.40
Total Income	5,790.60	34,275.00	-28,484.40
Gross Profit	5,790.60	34,275.00	-28,484.40
Expense			
Aflac (Health Insurance)	0.00	0.00	0.00
Audit	0.00	0.00	0.00
Bank Fees	0.00	22.00	-22.00
Cleaning supplies	868.28	500.00	368.28
Director stipends	0.00	1,000.00	-1,000.00
District counsel	780.00	1,000.00	-220.00
District Payroll Taxes	1,294.37	1,392.00	-97.63
Electricity	3,357.46	2,650.00	707.46
Employee Salaries	14,560.94	15,547.00	-986.06
Equipment Fuel	264.00	150.00	114.00
Event Costs	0.00	225.00	-225.00
Fresno co Service fee	0.00	0.00	0.00
Fresno co Service fee	0.00	144.00	-144.00
HR miscellaneous	159.99	170.00	-10.01
Internet	159.33	160.00	-0.67
Landline Phone	0.00	0.00	0.00
Liability insurance	0.00	620.00	-620.00
Memberships	0.00	0.00	0.00
Mileage	98.43	120.00	-21.57
Mobile Phone	0.00	170.00	-170.00
Office Equipment	0.00	170.00	-170.00
Office Supply	924.66	100.00	824.66
Office Supply	219.93	208.00	11.93
Payroll Fees	0.00	0.00	0.00
Professional Development	0.00	500.00	-500.00
Recreation Programs	-192.09	500.00	-692.09
Repairs and Maintenance	3,354.68	2,500.00	854.68
Security	0.00	0.00	0.00
Security	10.00	10.00	0.00
Security Monitoring System	0.00	90.00	-90.00
Technology Service	0.00	90.00	-90.00
Technology Service	242.73	250.00	-7.27
Trash Disposal	-17,052.08	375.00	-17,427.08
Vehicle Leasing	5,279.25	4,200.00	1,079.25
Water	0.00	0.00	0.00
Workers Compensation	0.00	0.00	0.00
Total Expense	14,329.88	32,103.00	-17,773.12
Net Ordinary Income	-8,539.28	2,172.00	-10,711.28
Net Income	-8,539.28	2,172.00	-10,711.28

Reconciliation Summary
Fresno County Account, Period Ending 08/31/2019

	Aug 31, 19
Beginning Balance	223,993.38
Cleared Transactions	
Checks and Payments - 22 items	-64,488.24
Deposits and Credits - 2 items	2,300.60
Total Cleared Transactions	-62,187.64
Cleared Balance	<u>161,805.74</u>
Register Balance as of 08/31/2019	161,805.74
Ending Balance	161,805.74

RECONCILIATION Detail
Fresno County Account, Period Ending 08/31/2019

Type	Date	Num	Name	Clr	Amount	Balance
Beginning Balance						223,993.38
Cleared Transactions						
Checks and Payments - 22 items						
Check	08/06/2019	65-0281654	ULINE	X	-2,576.22	-2,576.22
Check	08/06/2019	65-0281658	Johnson Controls Fir...	X	-641.00	-3,217.22
Check	08/06/2019	65-0281651	Home Depot Credit ...	X	-539.73	-3,756.95
Check	08/06/2019	65-0281659	Air Comfot Solutions...	X	-419.25	-4,176.20
Check	08/06/2019	65-0281653	Unifirst	X	-399.51	-4,575.71
Check	08/06/2019	65-0281657	Central Sanitary Sup...	X	-352.19	-4,927.90
Check	08/06/2019	65-0281652	Mid Valley Disposal	X	-242.73	-5,170.63
Check	08/06/2019	65-0281650	AT and T	X	-159.33	-5,329.96
Check	08/06/2019	65-0281649	John Deere Financial	X	-134.27	-5,464.23
Check	08/06/2019	65-0281655	Verizon Wireless	X	-98.43	-5,562.66
Check	08/08/2019	65-0281660	Montoy Law Corpora...	X	-780.00	-6,342.66
Check	08/23/2019	65-0284900	Calwa Recreation a...	X	-24,000.00	-30,342.66
Check	08/23/2019	65-0284901	Calwa Recreation a...	X	-20,000.00	-50,342.66
Check	08/23/2019	65-0281646	Calwa Recreation a...	X	-7,662.82	-58,005.48
Check	08/23/2019	65-0284899	City of Fresno Utilities	X	-5,279.25	-63,284.73
Check	08/23/2019	65-0284896	Office Depot Credit ...	X	-473.35	-63,758.08
Check	08/23/2019	65-0281648	KS StateBank	X	-162.53	-63,920.61
Check	08/23/2019	65-0281645	Unwired Broadband ...	X	-159.99	-64,080.60
Check	08/23/2019	65-0284897	Iduvina Chavez	X	-150.00	-64,230.60
Check	08/23/2019	65-0281647	Unifirst	X	-116.58	-64,347.18
Check	08/23/2019	65-0284902	Gunner Santos	X	-74.06	-64,421.24
Check	08/23/2019	65-0284898	ULINE	X	-67.00	-64,488.24
Total Checks and Payments					-64,488.24	-64,488.24
Deposits and Credits - 2 items						
Check	08/06/2019	65-0281656	Unifirst	X	0.00	0.00
Deposit	08/31/2019			X	2,300.60	2,300.60
Total Deposits and Credits					2,300.60	2,300.60
Total Cleared Transactions					-62,187.64	-62,187.64
Cleared Balance					-62,187.64	161,805.74
Register Balance as of 08/31/2019					-62,187.64	161,805.74
Ending Balance					<u>-62,187.64</u>	<u>161,805.74</u>

Report ID: GISF9109
 Program: GISF9109

PeopleSoft
 MONTHLY GENERAL LEDGER TRIAL BALANCE

Fiscal Year 2020
 Through Period 2

Page No. 1
 Run Date 09/04/2019
 Run Time 08:48:18

Fund:	4660	Beginning Balance		Year-to-Date Transaction		Current Balances	
Salwa Park And Recreation Dist		Debit Accts	Credit Accts	Debits	Credits	Debits Accts	Credit Accts
Subclass: 10000							
General Subclass							
0110 Cash In Treasury		279,610.17	0.00	0.00	117,804.43	161,805.74	0.00
0315 Interest Receivable		1,460.13	0.00	0.00	103.59	1,356.54	0.00
1435 Due To Other Governmental		0.00	1,619,309.92	0.00	0.00	0.00	1,619,309.92
1480 Fiduciary Closing		0.00	1,341,672.42	0.00	0.00	0.00	1,341,672.42
2230 Fund Balance - Unassigned		0.00	-2,679,912.04	120,208.62	2,300.60	0.00	-2,800,120.66
3011 Suppl-Current Secured		0.00	0.00	0.00	0.00	0.00	2,300.60
3380 Interest		0.00	0.00	0.00	0.00	0.00	0.00
SUB CLASS TOTAL		281,070.30	281,070.30	120,208.62	120,208.62	163,162.28	163,162.28

End of Report

Report ID: GISF9109
Program: GISF9109

PeopleSoft
MONTHLY GENERAL LEDGER TRIAL BALANCE
Fiscal Year 2020
Through Period 2

Page No. 2
Run Date 09/04/2019
Run Time 08:48:18

Fund: 4660
Calwa Park And Recreation Dist
Subclass: 10000
General Subclass

Beginning Balance	Year-to-Date	Transaction	Current	Balances
Debit Accts	Debits	Credits	Debits Accts	Credit Accts
281,070.30	120,208.62	120,208.62	163,162.28	163,162.28
GRAND TOTALS				

End of Report

Report ID: GLSF9100
 Program: GLSF9100

MONTHLY GENERAL LEDGER TRANSACTION REGISTER

Journal Dates 08/01/2019 through 08/31/2019

Run Time 08:48:18

Fund: 4660 Calwa Park And Recreation Dist SUBCLASS: 10000 ACCOUNT: 0110

Journal Date	Jrnl Src	Jrnl ID	Header Description	Line Ref	Debit Amount	Credit Amount
Sub class: 10000 General Subclass						
Account: 0110						
			Beginning Balance			223,993.38
08/09/2019	AUD	0001878638	20 - CURRENT SECURED SUPPL CSS12		2,300.60	
08/14/2019	REC	0001879216	Op Fund Entry - Main			6,342.66
08/26/2019	REC	0001881380	Op Fund Entry - Main			58,145.58
			Cash In Treasury		2,300.60	
			Ending Balance			161,805.74
Account: 2230						
Fund Balance - Unassigned						
			Beginning Balance			2,735,632.42
08/14/2019	REC	0001879216	Op Fund Entry - Main		6,342.66	
08/26/2019	REC	0001881380	Op Fund Entry - Main			58,145.58
			Fund Balance - Unassigned			2,800,120.66
			Ending Balance			0.00
Account: 3011						
Fund Balance - Unassigned						
			Beginning Balance			0.00
08/09/2019	AUD	0001878638	20 - CURRENT SECURED SUPPL CSS12		0.00	
			Suppl-Current Secured			2,300.60
			Ending Balance			-2,300.60
Subclass Total						
					66,788.84	66,788.84
Fund Total						
					66,788.84	66,788.84

End of Report

Reconciliation Summary
Bank of the West Payroll, Period Ending 08/31/2019

	<u>Aug 31, 19</u>
Beginning Balance	15,246.08
Cleared Transactions	
Checks and Payments - 9 Items	-16,077.01
Deposits and Credits - 6 Items	48,707.48
	<u>32,630.47</u>
Total Cleared Transactions	
Cleared Balance	<u>47,876.55</u>
Register Balance as of 08/31/2019	47,876.55
Ending Balance	47,876.55

RECONCILIATION Detail
Bank of the West Payroll, Period Ending 08/31/2019

Type	Date	Num	Name	Cir	Amount	Balance
						15,246.08
Beginning Balance						
Cleared Transactions						
Checks and Payments - 9 items						
Check	08/02/2019	DEBIT	ADP	X	-1,915.86	-1,915.86
Check	08/02/2019	DEBIT	ADP	X	-73.31	-1,989.17
Check	08/05/2019	DEBIT	ADP	X	-6,375.19	-8,364.36
Check	08/09/2019	DEBIT	ADP	X	-73.31	-8,437.67
Check	08/20/2019	DEBIT	ADP	X	-4,914.96	-13,352.63
Check	08/20/2019	DEBIT	ADP	X	-1,702.57	-15,055.20
Check	08/21/2019	11020	Robert Otero	X	-831.14	-15,886.34
Check	08/21/2019	985018	Aflac Health	X	-117.36	-16,003.70
Check	08/30/2019	DEBIT	ADP	X	-73.31	-16,077.01
Total Checks and Payments					-16,077.01	-16,077.01
Deposits and Credits - 6 items						
Check	07/30/2019	65-0281661	Calwa Recreation a...	X	8,422.10	8,422.10
Check	07/30/2019	65-0281664	Calwa Recreation a...	X	8,505.20	16,927.30
Deposit	08/05/2019			X	58.68	16,985.98
Deposit	08/20/2019			X	58.68	17,044.66
Check	08/23/2019	65-0281646	Calwa Recreation a...	X	7,662.82	24,707.48
Check	08/23/2019	65-0284900	Calwa Recreation a...	X	24,000.00	48,707.48
Total Deposits and Credits					48,707.48	48,707.48
Total Cleared Transactions					32,630.47	32,630.47
Cleared Balance					32,630.47	47,876.55
Register Balance as of 08/31/2019					32,630.47	47,876.55
Ending Balance					32,630.47	47,876.55



BANK OF THE WEST
BNP PARIBAS

P.O. Box 2830, Omaha, NE 68103-2830

Account Statement

August 1, 2019 - August 31, 2019

Page 1 of 6

CALWA RECREATION & PARK DISTRICT
 4545 E CHURCH AVE
 FRESNO CA 93725-1537

At your service



bankofthewest.com



1-800-488-2265



1-800-659-5495 TTY/TDD

New online and mobile services!

Enjoy these new online card services: Online statements - Online and recurring payments - Dispute transactions - Travel notices - PIN change - Account alerts - Replacement cards - Card activation - Lock/unlock your card.

Simply log into your account at www.bankofthewest.com and go to the Services and Support page or on your mobile device on the More screen.

Remember to confirm your email during your next branch visit or call our Contact Center at 800-488-2265. Our emails keep you educated about our services, products and more.

REGULAR BUSINESS CHECKING

CALWA RECREATION & PARK DISTRICT

ACCOUNT SUMMARY

Beginning Balance	\$15,246.08
6 Credits	117.36
2 Deposits	48,590.12
7 Withdrawals	-15,128.51
2 Checks	-948.50
Ending Balance	\$47,876.55

EARNINGS SUMMARY

Interest this statement period	\$0.00
Interest credited year-to-date	\$0.00
Annual percentage yield earned	0.00%
Average monthly balance	\$22,561.00

For your protection:

Examine this statement promptly. Any discrepancy must be reported within 30 days. Consumer customers: A discrepancy regarding an electronic payment or line of credit must be reported within 60 days.

In South Dakota, Bank of the West operates under the name of Bank of the West California.





REGULAR BUSINESS CHECKING xxx-xx5854 (continued)

ACCOUNT DETAIL

Credits

<u>Date</u>	<u>Amount</u>	<u>Description</u>
08/05	\$12.42	ELECTRONIC DEP CALWA RECREATION DIRECT DEP 080519PPD
08/05	16.32	ELECTRONIC DEP CALWA RECREATION DIRECT DEP 080519PPD
08/05	29.94	ELECTRONIC DEP CALWA RECREATION DIRECT DEP 080519PPD
08/20	12.42	ELECTRONIC DEP CALWA RECREATION DIRECT DEP 082019PPD
08/20	16.32	ELECTRONIC DEP CALWA RECREATION DIRECT DEP 082019PPD
08/20	29.94	ELECTRONIC DEP CALWA RECREATION DIRECT DEP 082019PPD

6 credits for a total of \$117.36

Deposits

<u>Date</u>	<u>Amount</u>	<u>Date</u>	<u>Amount</u>
08/07	\$16,927.30	08/28	\$31,662.82

2 deposits for a total of \$48,590.12

Withdrawals

<u>Date</u>	<u>Amount</u>	<u>Description</u>
08/02	\$73.31	ELECTRONIC DBT ADP PAYROLL FEES ADP - FEES 080219 2RJIG 5515724 CCD
08/02	1,915.86	ELECTRONIC DBT ADP Tax ADP Tax 080219 RRJIG 080516A01 CCD
08/05	6,375.19	ELECTRONIC DBT ADP WAGE PAY WAGE PAY 080519 942510809402JIG CCD
08/09	73.31	ELECTRONIC DBT ADP PAYROLL FEES ADP - FEES 080919 2RJIG 6071859 CCD
08/20	1,702.57	ELECTRONIC DBT ADP Tax ADP Tax 082019 RRJIG 082017A01 CCD
08/20	4,914.96	ELECTRONIC DBT ADP WAGE PAY WAGE PAY 082019 658071246304JIG CCD
08/30	73.31	ELECTRONIC DBT ADP PAYROLL FEES ADP - FEES 083019 2RJIG 0453993 CCD

7 withdrawals for a total of \$15,128.51

Checks Paid

<u>Number</u>	<u>Date paid</u>	<u>Amount</u>	<u>Number</u>	<u>Date paid</u>	<u>Amount</u>
11020	08/21	831.14	985018*	08/05	117.36

2 checks paid for a total of \$948.50

* Break in check number sequence.





IMPORTANT INFORMATION

IN CASE OF ERRORS OR QUESTIONS ABOUT YOUR ELECTRONIC TRANSFERS (For accounts that are maintained primarily for personal, family or household purposes.)

Telephone us at (800) 488-2265, or write us at Bank of the West*, Branch Service Center, P.O. Box 2573, Omaha, NE 68103-2573 as soon as you can if you think your statement or receipt is wrong or if you need more information about a transfer listed on the statement or receipt. We must hear from you no later than 60 days after we sent you the FIRST statement on which the error or problem appeared. We will need to know the following:

1. Tell us your name and account number (if any).
2. Describe the error or the transfer you are unsure about, and explain as clearly as you can why you believe it is an error or why you need more information.
3. Tell us the dollar amount of the suspected error.

We will investigate your complaint and will correct any error promptly. If we take more than 10 business days (20 business days for transactions involving new accounts) to do this, we will credit your account for the amount you think is in error, so that you will have the use of the money during the time it takes us to complete our investigation.

00909 3325818 001919 003837 0002/0003

*In South Dakota, Bank of the West operates under the name of Bank of the West California.





BANK OF THE WEST
BNP PARIBAS

Account Statement

August 1, 2019 - August 31, 2019

Page 4 of 6

This space intentionally left blank.



bankofthewest.com



1-800-488-2265



1-800-659-5495 TTY/TDD



BANK OF THE WEST
BNP PARIBAS

Account Statement

August 1, 2019 - August 31, 2019

Page 6 of 6

This space intentionally left blank.



bankofthewest.com



1-800-488-2265



1-800-659-5495 TTY/TDD

Reconciliation Summary

Bank of The West Revenue, Period Ending 08/31/2019

	Aug 31, 19
Beginning Balance	22,077.01
Cleared Transactions	
Checks and Payments - 15 items	-4,888.10
Deposits and Credits - 5 items	42,948.88
	<hr/>
Total Cleared Transactions	38,060.78
	<hr/>
Cleared Balance	60,137.79
	<hr/> <hr/>
Register Balance as of 08/31/2019	60,137.79
Ending Balance	60,137.79

Reconciliation Detail

Bank of The West Revenue, Period Ending 08/31/2019

Type	Date	Num	Name	Clr	Amount	Balance
Beginning Balance						22,077.01
Cleared Transactions						
Checks and Payments - 15 items						
Check	08/02/2019	DEBIT	Costco	X	-69.19	-69.19
Check	08/02/2019	DEBIT	Arco	X	-68.35	-137.54
Check	08/02/2019	DEBIT	Costco	X	-33.72	-171.26
Check	08/08/2019	DEBIT	Valley Iron	X	-34.88	-206.14
Check	08/12/2019	DEBIT	Arco	X	-67.35	-273.49
Check	08/13/2019	DEBIT	Amazon.com	X	-341.65	-615.14
Check	08/14/2019	DEBIT	PG and E	X	-3,357.46	-3,972.60
Check	08/15/2019	DEBIT	Office Depot	X	-451.31	-4,423.91
Check	08/15/2019	DEBIT	Amazon.com	X	-234.95	-4,658.86
Check	08/15/2019	DEBIT	Walmart	X	-25.00	-4,683.86
Check	08/15/2019	DEBIT	Walmart	X	-25.00	-4,708.86
Check	08/19/2019	DEBIT	Arco	X	-66.95	-4,775.81
Check	08/20/2019	DEBIT	RING.COM	X	-10.00	-4,785.81
Check	08/21/2019	DEBIT	Walmart	X	-40.94	-4,826.75
Check	08/29/2019	DEBIT	Arco	X	-61.35	-4,888.10
Total Checks and Payments					-4,888.10	-4,888.10
Deposits and Credits - 5 items						
Deposit	08/07/2019			X	3,625.00	3,625.00
Deposit	08/15/2019			X	1,050.00	4,675.00
Check	08/23/2019	65-0284901	Calwa Recreation and Park District	X	20,000.00	24,675.00
Deposit	08/26/2019			X	18,248.88	42,923.88
Deposit	08/28/2019			X	25.00	42,948.88
Total Deposits and Credits					42,948.88	42,948.88
Total Cleared Transactions					38,060.78	38,060.78
Cleared Balance					38,060.78	60,137.79
Register Balance as of 08/31/2019					38,060.78	60,137.79
Ending Balance					38,060.78	60,137.79



BANK OF THE WEST
BNP PARIBAS

P.O. Box 2830, Omaha, NE 68103-2830

Account Statement

August 1, 2019 - August 31, 2019

Page 1 of 4

CALWA RECREATION & PARK DISTRICT
 4545 E CHURCH AVE
 FRESNO CA 93725-1537

At your service



bankofthewest.com



1-800-488-2265



1-800-659-5495 TTY/TDD

New online and mobile services!

Enjoy these new online card services: Online statements - Online and recurring payments - Dispute transactions - Travel notices - PIN change - Account alerts - Replacement cards - Card activation - Lock/unlock your card.

Simply log into your account at www.bankofthewest.com and go to the Services and Support page or on your mobile device on the More screen.

Remember to confirm your email during your next branch visit or call our Contact Center at 800-488-2265. Our emails keep you educated about our services, products and more.

CLASSIC BUSINESS CHECKING

CALWA RECREATION & PARK DISTRICT

ACCOUNT SUMMARY

Beginning Balance	\$22,077.01
1 Credits	10.00
4 Deposits	42,948.88
16 Withdrawals	-4,898.10
0 Checks	0.00
Ending Balance	\$60,137.79

EARNINGS SUMMARY

Interest this statement period	\$0.00
Interest credited year-to-date	\$0.00
Annual percentage yield earned	0.00%
Average monthly balance	\$28,840.86

For your protection:

Examine this statement promptly. Any discrepancy must be reported within 30 days. Consumer customers: A discrepancy regarding an electronic payment or line of credit must be reported within 60 days.

In South Dakota, Bank of the West operates under the name of Bank of the West California.





CLASSIC BUSINESS CHECKING xxx-xx8101 (continued)

ACCOUNT DETAIL

Credits

<i>Date</i>	<i>Amount</i>	<i>Description</i>
08/01	\$10.00	SERVICE CHG REBATE VALUED CUSTOMER MONTHLY SERVICE CHARGE REBATE
1 credit for a total of \$10.00		

Deposits

<i>Date</i>	<i>Amount</i>	<i>Date</i>	<i>Amount</i>
08/07	\$3,625.00	08/26	\$18,248.88
08/15	1,050.00	08/28	20,025.00
4 deposits for a total of \$42,948.88			

Withdrawals

<i>Date</i>	<i>Amount</i>	<i>Description</i>
08/01	\$10.00	MONTHLY SVC CHG PREVIOUS PERIOD ACTIVITY RESULTED IN MONTHLY SERVICE CHARGE
08/02	68.35	POS PURCHASE 044001 ARCO #42744 FRESNO CA ##9455
08/02	69.19	POS PURCHASE 572057 COSTCO WHSE #06 FRESNO CA ##9455
08/02	33.72	POS PURCHASE 573643 COSTCO WHSE #06 FRESNO CA ##9455
08/08	34.88	DEBIT CARD POS VALLEY IRON, INC. FRESNO CA ON 190808 #9455
08/12	67.35	POS PURCHASE 044001 ARCO #42744 FRESNO CA ##9455
08/13	341.65	POS PURCHASE 820252 PAYPAL *DEALFR San Jose CA ##9455
08/14	3,357.46	ELECTRONIC DBT PGANDE WEB ONLINE 081419 WEB
08/15	451.31	DEBIT CARD POS OFFICE DEPOT 1135 800-463-3768 CA ON 190815 #9455
08/15	234.95	POS PURCHASE 647575 AMAZON.COM*MA8 SEATTLE WA ##9455
08/15	25.00	POS PURCHASE 888043 Wal-Mart Super FRESNO CA ##9455
08/15	25.00	POS PURCHASE 298284 WAL-MART #2001 FRESNO CA ##9455
08/19	66.95	POS PURCHASE 044001 ARCO #42744 FRESNO CA ##9455
08/20	10.00	DEBIT CARD POS RING UNLIMITED MONTHLY 8006561918 CA ON 190820 #7602
08/21	40.94	POS PURCHASE 856443 Walmart.com Bentonville AR ##9455
08/29	61.35	POS PURCHASE 044001 ARCO #42744 FRESNO CA ##9455
16 withdrawals for a total of \$4,898.10		





IMPORTANT INFORMATION

IN CASE OF ERRORS OR QUESTIONS ABOUT YOUR ELECTRONIC TRANSFERS (For accounts that are maintained primarily for personal, family or household purposes.)



Telephone us at (800) 488-2265, or write us at Bank of the West*, Branch Service Center, P.O. Box 2573, Omaha, NE 68103-2573 as soon as you can if you think your statement or receipt is wrong or if you need more information about a transfer listed on the statement or receipt. We must hear from you no later than 60 days after we sent you the FIRST statement on which the error or problem appeared. We will need to know the following:

1. Tell us your name and account number (if any).
2. Describe the error or the transfer you are unsure about, and explain as clearly as you can why you believe it is an error or why you need more information.
3. Tell us the dollar amount of the suspected error.

We will investigate your complaint and will correct any error promptly. If we take more than 10 business days (20 business days for transactions involving new accounts) to do this, we will credit your account for the amount you think is in error, so that you will have the use of the money during the time it takes us to complete our investigation.

09621 3324999 018540 037079 0002/0002

*In South Dakota, Bank of the West operates under the name of Bank of the West California.





BANK OF THE WEST
BNP PARIBAS

Account Statement

August 1, 2019 - August 31, 2019

Page 4 of 4

This space intentionally left blank.



bankofthewest.com



1-800-488-2265



1-800-659-5495 TTY/TDD

	Jul-19	Aug-19	Sep-19	Oct-19	Nov-19	Dec-19	Jan-20	Feb-20	Mar-19	Apr-19	May-19	Jun-20	YTD TOTAL	Dollar	Percentage Left	
Employee Cost																
Employee Salaries	\$ 17,647.00	\$ 15,547.00	\$ 15,547.00	\$ 22,878.00	\$ 15,547.00	\$ 15,547.00	\$ 15,547.00	\$ 15,547.00	\$ 22,879.00	\$ 16,547.00	\$ 16,547.00	\$ 19,102.00	\$ 209,882.00	\$ 165,544.28	79.25%	
vacation	\$ 75.00	\$ 75.00	\$ 75.00	\$ 75.00	\$ 75.00	\$ 75.00	\$ 75.00	\$ 200.00	\$ 200.00	\$ 200.00	\$ 200.00	\$ 200.00	\$ 1,525.00			
Payroll Taxes	\$ 1,392.00	\$ 1,392.00	\$ 1,392.00	\$ 2,169.00	\$ 1,392.00	\$ 1,392.00	\$ 1,392.00	\$ 1,392.00	\$ 2,169.00	\$ 1,392.00	\$ 1,392.00	\$ 1,392.00	\$ 18,258.00			
Payroll Fees	\$ 268.00	\$ 268.00	\$ 268.00	\$ 268.00	\$ 268.00	\$ 268.00	\$ 268.00	\$ 268.00	\$ 268.00	\$ 268.00	\$ 268.00	\$ 268.00	\$ 2,496.00			
Director Stipends	\$ 1,000.00	\$ 1,000.00	\$ 500.00	\$ 500.00	\$ 500.00	\$ 500.00	\$ 500.00	\$ 500.00	\$ 500.00	\$ 500.00	\$ 500.00	\$ 1,000.00	\$ 7,800.00	\$ 5,900.00	70.67%	
Director Compensation	\$ 8,000.00	\$ -	\$ -	\$ -	\$ -	\$ -	\$ -	\$ -	\$ -	\$ -	\$ -	\$ -	\$ 8,000.00	\$ 7,820.54	97.76%	
Miscellaneous	\$ 144.00	\$ 144.00	\$ 144.00	\$ 144.00	\$ 144.00	\$ 144.00	\$ 144.00	\$ 144.00	\$ 144.00	\$ 144.00	\$ 144.00	\$ 144.00	\$ 1,728.00			
Other	\$ 325.09	\$ 2,899.46	\$ 2,899.46	\$ (1,324.73)	\$ 17,866.00	\$ 17,866.00	\$ 17,866.00	\$ 17,866.00	\$ 17,866.00	\$ 17,866.00	\$ 17,866.00	\$ 22,046.60	\$ 248,388.00	\$ (171.82)	-9.94%	
	\$ 28,466.00	\$ 16,075.24	\$ 21,446.24	\$ (1,324.73)	\$ 17,866.00	\$ 17,866.00	\$ 17,866.00	\$ 17,866.00	\$ 17,866.00	\$ 17,866.00	\$ 17,866.00	\$ 22,046.60	\$ 248,388.00	\$ 196,598.09	79.15%	
	\$ 15,594.16	\$ 16,075.24	\$ 21,446.24	\$ (1,324.73)	\$ 17,866.00	\$ 17,866.00	\$ 17,866.00	\$ 17,866.00	\$ 17,866.00	\$ 17,866.00	\$ 17,866.00	\$ 22,046.60	\$ 248,388.00	\$ 196,598.09	79.15%	
Expenses																
audit	\$ -	\$ -	\$ -	\$ -	\$ -	\$ -	\$ 8,000.00	\$ -	\$ -	\$ -	\$ -	\$ -	\$ -	\$ 8,000.00		
bank fees	\$ 22.00	\$ 22.00	\$ 22.00	\$ 22.00	\$ 22.00	\$ 22.00	\$ 22.00	\$ 22.00	\$ 22.00	\$ 22.00	\$ 22.00	\$ 22.00	\$ 264.00	\$ 8,000.00	100.00%	
cleaning supplies	\$ 1,200.00	\$ 500.00	\$ 500.00	\$ 400.00	\$ 500.00	\$ 300.00	\$ 350.00	\$ 500.00	\$ 800.00	\$ 350.00	\$ 500.00	\$ 500.00	\$ 6,400.00	\$ 263.50	99.81%	
direct counsel	\$ 1,000.00	\$ 1,000.00	\$ 1,000.00	\$ 1,000.00	\$ 1,000.00	\$ 1,000.00	\$ 1,000.00	\$ 1,000.00	\$ 1,000.00	\$ 1,000.00	\$ 1,000.00	\$ 1,000.00	\$ 12,000.00	\$ 4,926.44	76.98%	
direct board elections	\$ -	\$ 3,000.00	\$ -	\$ -	\$ -	\$ -	\$ -	\$ -	\$ -	\$ -	\$ -	\$ -	\$ 3,000.00	\$ 10,395.00	86.63%	
electricity	\$ 3,650.00	\$ 2,650.00	\$ 3,750.00	\$ 2,750.00	\$ 2,610.00	\$ 3,050.00	\$ 2,750.00	\$ 3,150.00	\$ 2,800.00	\$ 3,650.00	\$ 3,150.00	\$ 2,888.00	\$ 36,198.00	\$ 26,231.61	72.47%	
equipment fuel	\$ 114.00	\$ 150.00	\$ 140.00	\$ 118.00	\$ 125.00	\$ 65.00	\$ 180.00	\$ 150.00	\$ 130.00	\$ 118.00	\$ 97.00	\$ 118.00	\$ 1,505.00	\$ 1,034.93	68.77%	
event costs	\$ 235.00	\$ 235.00	\$ 235.00	\$ 235.00	\$ 235.00	\$ 235.00	\$ 235.00	\$ 235.00	\$ 235.00	\$ 235.00	\$ 235.00	\$ 235.00	\$ 2,700.00	\$ 2,700.00	100.00%	
renewal service fees	\$ -	\$ -	\$ -	\$ -	\$ -	\$ -	\$ -	\$ -	\$ -	\$ -	\$ -	\$ 750.00	\$ 750.00	\$ 750.00	100.00%	
ability insurance	\$ 5,000.00	\$ -	\$ -	\$ -	\$ -	\$ -	\$ 5,000.00	\$ -	\$ -	\$ -	\$ -	\$ -	\$ 10,000.00	\$ 10,000.00	100.00%	
internet	\$ 180.00	\$ 170.00	\$ 210.00	\$ 186.00	\$ 210.00	\$ 210.00	\$ 200.00	\$ 166.00	\$ 210.00	\$ 210.00	\$ 170.00	\$ 201.00	\$ 2,803.00	\$ 1,663.04	72.21%	
landline phone	\$ 120.00	\$ 160.00	\$ 120.00	\$ 120.00	\$ 160.00	\$ 160.00	\$ 130.00	\$ 100.00	\$ 160.00	\$ 160.00	\$ 160.00	\$ 210.00	\$ 1,878.00	\$ 1,235.25	66.06%	
mobile phone	\$ 120.00	\$ 120.00	\$ 120.00	\$ 120.00	\$ 120.00	\$ 120.00	\$ 120.00	\$ 120.00	\$ 120.00	\$ 120.00	\$ 120.00	\$ 120.00	\$ 1,440.00	\$ 1,153.95	80.14%	
memberships	\$ 93.01	\$ 98.43	\$ 94.61	\$ -	\$ -	\$ 1,900.00	\$ -	\$ -	\$ -	\$ -	\$ -	\$ -	\$ 1,920.00	\$ 1,920.00	100.00%	
miscellaneous	\$ 100.00	\$ -	\$ -	\$ -	\$ -	\$ -	\$ -	\$ -	\$ -	\$ -	\$ -	\$ -	\$ 100.00	\$ 100.00	100.00%	
office equipment	\$ 210.00	\$ 170.00	\$ 170.00	\$ 100.00	\$ 180.00	\$ 175.00	\$ 170.00	\$ 200.00	\$ 275.00	\$ 150.00	\$ 150.00	\$ 150.00	\$ 2,100.00	\$ 1,672.62	79.65%	
office supplies	\$ 85.00	\$ 100.00	\$ 50.00	\$ 170.00	\$ 180.00	\$ 296.00	\$ 70.00	\$ 50.00	\$ 270.00	\$ 131.00	\$ 85.00	\$ 85.00	\$ 1,871.00	\$ 1,426.66	92.52%	
professional development	\$ -	\$ -	\$ -	\$ -	\$ 1,000.00	\$ -	\$ -	\$ -	\$ -	\$ -	\$ -	\$ -	\$ 1,000.00	\$ 1,000.00	100.00%	
recreation programs	\$ 600.00	\$ 500.00	\$ 400.00	\$ 400.00	\$ 400.00	\$ 300.00	\$ 300.00	\$ 308.00	\$ 308.00	\$ 450.00	\$ 450.00	\$ 450.00	\$ 4,858.00	\$ 4,811.53	99.04%	
repair and maintenance	\$ 408.56	\$ (192.09)	\$ (170.00)	\$ 4,800.00	\$ 5,000.00	\$ 5,000.00	\$ 5,000.00	\$ 5,000.00	\$ 5,000.00	\$ 3,500.00	\$ 3,500.00	\$ 3,500.00	\$ 52,300.00	\$ 52,300.00	100.00%	
security	\$ 9,006.51	\$ 3,354.68	\$ 2,513.11	\$ 500.00	\$ 500.00	\$ 500.00	\$ 500.00	\$ 350.00	\$ 500.00	\$ 500.00	\$ 500.00	\$ 500.00	\$ 2,350.00	\$ 2,350.00	100.00%	
county monitoring system	\$ 486.00	\$ 10.00	\$ 10.00	\$ 260.00	\$ 10.00	\$ 10.00	\$ 10.00	\$ 10.00	\$ 10.00	\$ 10.00	\$ 10.00	\$ 10.00	\$ 620.00	\$ 1,864.00	79.32%	
technology services	\$ 90.00	\$ 90.00	\$ 90.00	\$ 90.00	\$ 120.00	\$ 120.00	\$ 100.00	\$ 90.00	\$ 100.00	\$ 90.00	\$ 100.00	\$ 90.00	\$ 1,170.00	\$ 182.83	29.49%	
rubbish disposal	\$ 250.00	\$ 350.00	\$ 250.00	\$ 250.00	\$ 250.00	\$ 250.00	\$ 250.00	\$ 250.00	\$ 250.00	\$ 250.00	\$ 250.00	\$ 250.00	\$ 3,000.00	\$ 945.00	80.77%	
vehicle leasing/financing	\$ 239.14	\$ 242.73	\$ 239.14	\$ 375.00	\$ 375.00	\$ 375.00	\$ 375.00	\$ 375.00	\$ 375.00	\$ 375.00	\$ 375.00	\$ 375.00	\$ 4,500.00	\$ 2,278.99	76%	
water	\$ 296.80	\$ (17,052.08)	\$ 296.80	\$ 3,600.00	\$ 4,400.00	\$ 2,850.00	\$ 2,000.00	\$ 2,000.00	\$ 1,500.00	\$ 2,500.00	\$ 2,500.00	\$ 2,650.00	\$ 35,000.00	\$ 20,958.48	466%	
winning pool maintenance	\$ 2,849.48	\$ 5,279.25	\$ 7,679.48	\$ 1,500.00	\$ -	\$ -	\$ -	\$ -	\$ -	\$ -	\$ -	\$ 1,500.00	\$ 3,000.00	\$ 3,000.00		
winning pool construction	\$ -	\$ -	\$ 80,000.00	\$ -	\$ -	\$ -	\$ -	\$ -	\$ -	\$ -	\$ -	\$ -	\$ 250,000.00	\$ 35,000.00	100.00%	
Total	\$ 18,251.00	\$ 16,812.00	\$ 101,032.00	\$ 15,766.00	\$ 16,287.00	\$ 65,828.00	\$ 26,792.00	\$ 13,978.00	\$ 63,905.00	\$ 13,901.00	\$ 12,864.00	\$ 84,544.00	\$ 449,250.00	\$ 416,850.00	93%	
	\$ 17,900.78	\$ (1,745.40)	\$ 16,146.62	\$ -	\$ -	\$ -	\$ -	\$ -	\$ -	\$ -	\$ -	\$ -	\$ 33,070.00	\$ -	-	
	\$ 46,710.00	\$ 35,178.00	\$ 119,888.00	\$ 41,740.00	\$ 94,153.00	\$ 29,625.00	\$ 44,618.00	\$ 31,960.00	\$ 81,886.00	\$ 40,000.00	\$ 31,855.00	\$ 106,590.00	\$ 698,309.00	\$ 613,448.09	88%	
Grand Total	\$ 33,494.94	\$ 14,329.84	\$ 38,360.86	\$ (1,324.73)	\$ -	\$ -	\$ -	\$ -	\$ -	\$ -	\$ -	\$ -	\$ 84,860.91	\$ 613,448.09	88%	

Profit & Loss Budget Overview

September 2019

	Sep 19	Budget
Ordinary Income/Expense		
Income		
Park Income (Income recieved from Park Rentals)		
Donation	0.00	50,000.00
Events	1,415.00	2,450.00
Field Rentals	0.00	150.00
Hall Rentals	250.00	100.00
Miscellaneous	0.00	1,450.00
Picnic Rental	135.00	100.00
Rent Payments	900.00	1,400.00
Zumba	600.00	600.00
Total Park Income (Income recieved from Park Rentals)	3,300.00	56,250.00
The County of Fresno		
2230-unassigned funds	0.00	0.00
3005-RDA ABX1 26 Property Tax	0.00	0.00
3006-Redev Tax Incrém Reimb	0.00	0.00
3008-Suppl-Prior Secured	0.00	0.00
3009-suppl-Current Unsecured	0.00	0.00
3010-Property Taxes	0.00	0.00
3011-Suppl-Current Secured	572.08	0.00
3015-Property Taxes-current Uns	1,356.54	0.00
3025-Property Taxes-Prior Unsec	193.19	0.00
3030-Penalties & Costs	0.00	0.00
3380-Interest	0.00	0.00
3565-State-/L Homeowners Prop	0.00	0.00
4369- Federal In lieu housing	0.00	0.00
5804-ABX126 Other Revenue	0.00	0.00
The County of Fresno - Other	0.00	28,025.00
Total The County of Fresno	2,121.81	28,025.00
Total Income	5,421.81	84,275.00
Gross Profit	5,421.81	84,275.00
Expense		
Aflac (Health Insurance)	-117.36	0.00
Audit	0.00	0.00
Bank Fees	0.50	22.00
Cleaning supplies	405.58	500.00
Director stipends	2,200.00	500.00
District counsel	675.00	1,000.00
District Payroll Taxes	1,497.12	1,392.00
Electricity	3,636.96	3,750.00
Employee Salaries	14,517.90	16,547.00
Equipment Fuel	137.71	140.00
Event Costs	0.00	225.00
Fresno co Service fee	0.00	0.00
HR miscellaneous	2,899.46	144.00
Internet	159.99	210.00
Landline Phone	317.70	120.00
Liability insurance	0.00	0.00
Memberships	0.00	0.00
Mileage	0.00	0.00
Mobile Phone	94.61	120.00
Office Equipment	161.37	170.00
Office Supply	274.50	50.00
Payroll Fees	152.30	208.00
Professional Development	0.00	0.00
Recreation Programs	-170.00	400.00
Repairs and Maintenance	2,513.11	8,000.00
Security	0.00	500.00
Security Monitoring System	417.17	10.00
Technology Service	75.00	90.00
Trash Disposal	239.14	250.00
Vehicle Leasing	296.80	375.00
Water	7,679.48	3,600.00
Workers Compensation	179.46	0.00
Total Expense	38,243.50	38,323.00
Net Ordinary Income	-32,821.69	45,952.00

Reconciliation Summary

Bank of The West Revenue, Period Ending 09/30/2019

	<u>Sep 30, 19</u>
Beginning Balance	60,137.79
Cleared Transactions	
Checks and Payments - 38 items	-22,813.00
Deposits and Credits - 1 item	6,119.46
	<u>-16,693.54</u>
Total Cleared Transactions	
Cleared Balance	<u>43,444.25</u>
Register Balance as of 09/30/2019	43,444.25
New Transactions	
Checks and Payments - 1 item	-200.00
Deposits and Credits - 1 item	20,000.00
	<u>19,800.00</u>
Total New Transactions	
Ending Balance	<u><u>63,244.25</u></u>

Reconciliation Detail

Bank of The West Revenue, Period Ending 09/30/2019

Type	Date	Num	Name	Clr	Amount	Balance
Beginning Balance						60,137.79
Cleared Transactions						
Checks and Payments - 38 items						
Check	09/03/2019	DEBIT	RING.COM	X	-407.17	-407.17
Check	09/03/2019	Debit	Bank of the West	X	-0.50	-407.67
Check	09/04/2019	DEBIT	Fresno Power Equipment	X	-20.00	-427.67
Check	09/05/2019	DEBIT	Jenson & Pilegard	X	-356.31	-783.98
Check	09/05/2019	DEBIT	Calpers	X	-250.00	-1,033.98
Check	09/06/2019	985003	Central Sanitary Supply	X	-141.74	-1,175.72
Check	09/06/2019	985005	Central Sanitary Supply	X	-63.54	-1,239.26
Check	09/06/2019	985004	Central Sanitary Supply	X	-44.92	-1,284.18
Check	09/09/2019	DEBIT	United Health Care	X	-2,649.46	-3,933.64
Check	09/09/2019	985002	Zoom Imaging Solutions INC	X	-78.40	-4,012.04
Check	09/10/2019	DEBIT	Arco	X	-64.36	-4,076.40
Check	09/11/2019	DEBIT	United Health Care	X	-2,649.46	-6,725.86
Check	09/12/2019	1110	Jeff Pfeiffer	X	-550.00	-7,275.86
Check	09/12/2019	1111	Jeff Pfeiffer	X	-550.00	-7,825.86
Check	09/12/2019	1108	SDRMA	X	-179.46	-8,005.32
Check	09/12/2019	1109	KS StateBank	X	-162.53	-8,167.85
Check	09/12/2019	DEBIT	Fresno Equipment Company	X	-44.57	-8,212.42
Check	09/12/2019	DEBIT	Amazon.com	X	-23.77	-8,236.19
Check	09/13/2019	DEBIT	Home Depot Credit Card Servi...	X	-673.51	-8,909.70
Check	09/13/2019	DEBIT	AT and T	X	-158.85	-9,068.55
Check	09/13/2019	DEBIT	John Deere Financial	X	-134.27	-9,202.82
Check	09/13/2019	DEBIT	Verizon Wireless	X	-94.61	-9,297.43
Check	09/13/2019	DEBIT	Jenson & Pilegard	X	-71.36	-9,368.79
Check	09/16/2019	DEBIT	AT and T	X	-158.85	-9,527.64
Check	09/17/2019	DEBIT	Office Depot	X	-274.50	-9,802.14
Check	09/17/2019	DEBIT	Mid Valley Disposal	X	-239.14	-10,041.28
Check	09/17/2019	985011	De Lage Landon	X	-82.97	-10,124.25
Check	09/17/2019	985010	Streamline	X	-75.00	-10,199.25
Check	09/18/2019	DEBIT	Amazon.com	X	-59.62	-10,258.87
Check	09/20/2019	DEBIT	RING.COM	X	-10.00	-10,268.87
Check	09/23/2019	DEBIT	PG and E	X	-3,636.96	-13,905.83
Check	09/23/2019	DEBIT	Fresno Power Equipment	X	-103.75	-14,009.58
Check	09/24/2019	DEBIT	Montoy Law Corporation	X	-675.00	-14,684.58
Check	09/24/2019	985019	Unwired Broadband Inc	X	-159.99	-14,844.57
Check	09/24/2019	DEBIT	Unifirst	X	-155.38	-14,999.95
Check	09/25/2019	985016	City of Fresno Utilities	X	-7,679.48	-22,679.43
Check	09/27/2019	DEBIT	Grainger.com	X	-60.22	-22,739.65
Check	09/30/2019	DEBIT	Arco	X	-73.35	-22,813.00
Total Checks and Payments					-22,813.00	-22,813.00
Deposits and Credits - 1 Item						
Deposit	09/19/2019			X	6,119.46	6,119.46
Total Deposits and Credits					6,119.46	6,119.46
Total Cleared Transactions					-16,693.54	-16,693.54
Cleared Balance					-16,693.54	43,444.25
Register Balance as of 09/30/2019					-16,693.54	43,444.25
New Transactions						
Checks and Payments - 1 Item						
Check	10/04/2019	1112	Alberto Martinez		-200.00	-200.00
Total Checks and Payments					-200.00	-200.00
Deposits and Credits - 1 item						
Check	10/04/2019	65-0284...	Calwa Recreation and Park Di...		20,000.00	20,000.00
Total Deposits and Credits					20,000.00	20,000.00
Total New Transactions					19,800.00	19,800.00
Ending Balance					3,106.46	63,244.25



BANK OF THE WEST
BNP PARIBAS

P.O. Box 2830, Omaha, NE 68103-2830

Account Statement

September 1, 2019 - September 30, 2019

Page 1 of 4

CALWA RECREATION & PARK DISTRICT
 4545 E CHURCH AVE
 FRESNO CA 93725-1537

At your service



bankofthewest.com



1-800-488-2265



1-800-659-5495 TTY/TDD

New online and mobile services!

Enjoy these new online card services: Online statements - Online and recurring payments - Dispute transactions - Travel notices - PIN change - Account alerts - Replacement cards - Card activation - Lock/unlock your card.

Simply log into your account at www.bankofthewest.com and go to the Services and Support page or on your mobile device on the More screen.

Remember to confirm your email during your next branch visit or call our Contact Center at 800-488-2265. Our emails keep you educated about our services, products and more.

CLASSIC BUSINESS CHECKING

CALWA RECREATION & PARK DISTRICT

ACCOUNT SUMMARY

Beginning Balance	\$60,137.79
1 Credits	10.00
1 Deposits	6,119.46
27 Withdrawals	-13,054.97
12 Checks	-9,768.03
Ending Balance	\$43,444.25

EARNINGS SUMMARY

Interest this statement period	\$0.00
Interest credited year-to-date	\$0.00
Annual percentage yield earned	0.00%
Average monthly balance	\$53,973.82

For your protection:

Examine this statement promptly. Any discrepancy must be reported within 30 days. Consumer customers: A discrepancy regarding an electronic payment or line of credit must be reported within 60 days.

In South Dakota, Bank of the West operates under the name of Bank of the West California.





CLASSIC BUSINESS CHECKING

(continued)

ACCOUNT DETAIL

Credits

Date	Amount	Description
09/03	\$10.00	SERVICE CHG REBATE VALUED CUSTOMER MONTHLY SERVICE CHARGE REBATE
1 credit for a total of \$10.00		

Deposits

Date	Amount
09/19	\$6,119.46
1 deposit for a total of \$6,119.46	

Withdrawals

Date	Amount	Description
09/03	\$407.17	DEBIT CARD POS SP * RING USA 8006561918 CA ON 190831 #9455
09/03	0.50	EXCESS CURR FEE PREVIOUS PERIOD ACTIVITY RESULTED IN FEE FOR EXCESS CURRENCY
09/03	10.00	MONTHLY SVC CHG PREVIOUS PERIOD ACTIVITY RESULTED IN MONTHLY SERVICE CHARGE
09/04	20.00	DEBIT CARD POS SQ *SQ *FRESNO POWER E FRESNO CA ON 190904 #9455
09/05	356.31	DEBIT CARD POS JENSON & PILEGARD #2 FRESNO CA ON 190905 #9455
09/05	250.00	ELECTRONIC DBT CALPERS 1900 090519 1404561148 CCD 100000015778857
09/09	2,649.46	ELECTRONIC DBT UNITED HEALTHCAR ONLINE PMT 090919 CKF412279708POS CCD
09/10	64.36	POS PURCHASE 044001 ARCO #42744 FRESNO CA ##9455
09/11	2,649.46	ELECTRONIC DBT UNITED HEALTHCAR EDI PAYMTS 091119 746549759380 CTX
09/12	44.57	DEBIT CARD POS FRESNO EQUIPMENT COMPA FRESNO CA ON 190912 #9455
09/12	23.77	POS PURCHASE 000003 AMAZON.COM*YFO SEATTLE WA ##9455
09/13	71.36	DEBIT CARD POS JENSON & PILEGARD #2 FRESNO CA ON 190913 #9455
09/13	94.61	ELECTRONIC DBT VERIZON ONLINE PMT 091319 CKF412279708POS CCD
09/13	134.27	ELECTRONIC DBT JOHN DEERE CREDIT ONLINE PMT 091319 CKF412279708POS CCD
09/13	158.85	ELECTRONIC DBT AT&T (PAC BELL) ONLINE PMT 091319 CKF412279708POS CCD
09/13	673.51	ELECTRONIC DBT THE HOME DEPOT R ONLINE PMT 091319 CKF412279708POS CCD
09/16	158.85	ELECTRONIC DBT AT&T (PAC BELL) ONLINE PMT 091619 CKF412279708POS CCD
09/17	239.14	ELECTRONIC DBT MID VALLEY DISP ONLINE PMT 091719 CKF412279708POS CCD
09/17	274.50	ELECTRONIC DBT OFFICE DEPOT ONLINE PMT 091719 CKF412279708POS CCD
09/18	59.62	POS PURCHASE 498413 AMAZON.COM*9T7 SEATTLE WA ##9455
09/20	10.00	DEBIT CARD POS RING UNLIMITED MONTHLY 8006561918 CA ON 190920 #7602
09/23	103.75	DEBIT CARD POS SQ *SQ *FRESNO POWER E VISALIA CA ON 190922 #9455
09/23	3,636.96	ELECTRONIC DBT PGANDE WEB ONLINE 092119 WEB
09/24	155.38	ELECTRONIC DBT UNIFIRST ONLINE PMT 092419 CKF412279708POS CCD
09/24	675.00	ELECTRONIC DBT MONTROY LAW CORPO ONLINE PMT 092419 CKF412279708POS CCD
09/27	60.22	DEBIT CARD POS GRAINGER 877-2022594 IL ON 190927 #9455
09/30	73.35	POS PURCHASE 044001 ARCO #42744 FRESNO CA ##9455
27 withdrawals for a total of \$13,054.97		

Checks Paid

Number	Date paid	Amount	Number	Date paid	Amount	Number	Date paid	Amount
1108	09/24	179.46	985002*	09/09	78.40	985010*	09/30	75.00
1109	09/24	162.53	985003	09/11	141.74	985011	09/20	82.97
1110	09/30	550.00	985004	09/11	44.92	985016*	09/27	7,679.48
1111	09/18	550.00	985005	09/11	63.54	985019*	09/23	159.99
12 checks paid for a total of \$9,768.03								

* Break in check number sequence.





IMPORTANT INFORMATION

IN CASE OF ERRORS OR QUESTIONS ABOUT YOUR ELECTRONIC TRANSFERS (For accounts that are maintained primarily for personal, family or household purposes.)



Telephone us at (800) 488-2265, or write us at Bank of the West*, Branch Service Center, P.O. Box 2573, Omaha, NE 68103-2573 as soon as you can if you think your statement or receipt is wrong or if you need more information about a transfer listed on the statement or receipt. We must hear from you no later than 60 days after we sent you the FIRST statement on which the error or problem appeared. We will need to know the following:

1. Tell us your name and account number (if any).
2. Describe the error or the transfer you are unsure about, and explain as clearly as you can why you believe it is an error or why you need more information.
3. Tell us the dollar amount of the suspected error.

We will investigate your complaint and will correct any error promptly. If we take more than 10 business days (20 business days for transactions involving new accounts) to do this, we will credit your account for the amount you think is in error, so that you will have the use of the money during the time it takes us to complete our investigation.

10582 3423703 020883 041765 0002/0002

*In South Dakota, Bank of the West operates under the name of Bank of the West California.





BANK OF THE WEST
BNP PARIBAS

Account Statement

September 1, 2019 - September 30, 2019

Page 4 of 4

This space intentionally left blank.



bankofthewest.com



1-800-488-2265



1-800-659-5495 TTY/TDD



CALWA RECREATION & PARK DISTRICT
 4545 E. CHURCH AVENUE
 FRESNO, CA 93726

BANK OF THE WEST
 90-078/1211

1108

9/12/2019

PAY TO THE ORDER OF **SDRMA**

\$**USD 179.46

One Hundred Seventy-Nine and 46/100***** DOLLARS

SDRMA
 1112 I street suite 300
 Sacramento Ca 95814

Esmeralda Zamon
Felipe

MEMO 67032

⑈001108⑈ ⑆121100782⑆ 036438101⑈

For Deposit Only
 Special District Risk Management Authority (SDRMA)
 811086523

Details on Back
 Signature Check Lock™ Signature Check

CASH ONLY (CALL CALWA FOR SECURITY FEATURES LISTED ON BACK) (PRINTED IN THE UNITED STATES OF AMERICA)



CALWA RECREATION & PARK DISTRICT
4545 E. CHURCH AVENUE
FRESNO, CA 93725

BANK OF THE WEST
80-078/1211

1109

9/12/2019

PAY TO THE ORDER OF **KS StateBank**

\$**USD 162.53

One Hundred Sixty-Two and 53/100 DOLLARS

KS StateBank
Government Financing Department
PO BOX 69
Manhattan, KS 66506-0069

Emeraldia Zamora
7/20/19

MEMO

⑈001109⑈ ⑆121100782⑆ 036438101⑈

>101101536< 20190924
KS STATEBANK
113 4

<0101101536> DWR 113 TRN 4 09/24/19

PLEASE TO THE CREDIT OF
THE WITHIN NAMED PAYEE
Absence Of Endorsement Guaranteed
KS StateBank

CASH ONLY IF ALL CHECKLOCK SECURITY FEATURES LISTED ON BACK INDICATE NO TAMPERING OR COPYING



CALWA RECREATION & PARK DISTRICT
4545 E. CHURCH AVENUE
FRESNO, CA 93725

BANK OF THE WEST
90-078/1211

1111

9/12/2019

PAY TO THE ORDER OF Jeff Pfeiffer

\$**USD 550.00

Five Hundred Fifty and 00/100..... DOLLARS

Jeff Pfeiffer
30732 Rd 196
Exeter, Ca 93221

Emerald Zamboni

MEMO

⑆00111⑆ ⑆12100782⑆ 036438101⑆

For Deposit Only - JPMC

Jeff Pfeiffer

PLEASE POST THIS PAYMENT FOR OUR MUTUAL CUSTOMER

Account: 101150

\$78.40

78/1211

Please Direct Any Questions To
(800) 243-2508
Online Bill Payment Processing Center

0000985002

September 06, 2019

CALWA RECREATION & PARK DISTRICT
4545 E CHURCH AVE
FRESNO, CA 93725-1537

BANK OF THE WEST

08054 3333863 011937 011637 00010003 1011936

MEMO: 2133106

DOLLARS

Pay SEVENTY EIGHT AND 40/100

\$ *****78.40

TO ZOOM IMAGING SOLUTIONS
THE PO BOX 846898
ORDER LOS ANGELES, CA 90084-0131
OF



06054

Void After 180 DAYS.
Signature On File
This check has been authorized
by your depositor



⑈ 985002⑈ ⑆ 21100782⑆ 03643810⑈

008019003

ENDORSEMENT TO THE ACCT OF THE
BANKD PAYEE-W/O PREJUDICE
VALDES RAZO BANK N.A.
10190003
Acct # 8000085402
Box Num: 846898
Date: 20190907

DO NOT WRITE STAMP OR SIGN BELOW THIS LINE
RESERVED FOR FINANCIAL INSTITUTION USE

Security features on this document include a Micro-Print
border, a color-coded background, a simulated watermark, and
a color-coded void feature. All features are available on the
front and back of the document. For more information, visit
www.frb.org or call 1-800-955-5867.
* FEDERAL RESERVE BOARD OF GOVERNORS REG CC

DOCUMENT CONTAINS COLOR IN BACKGROUND ON WHITE PAPER - VOID FEATURE, SIMULATED WATERMARK (REVERSE SIDE), MICRO PRINT BORDER

Account: 18950

PLEASE POST THIS PAYMENT FOR OUR MUTUAL CUSTOMER

\$141.74

78/1211

Please Direct Any Questions To
(800) 243-2508
Online Bill Payment Processing Center

0000985003

September 06, 2019

CALWA RECREATION & PARK DISTRICT
4545 E CHURCH AVE
FRESNO, CA 93726-1537

BANK OF THE WEST

01160 3333861 002027 002027 0001/0007 0002026

MEMO: 1001423

DOLLARS

Pay ONE HUNDRED FORTY ONE AND 74/100

\$ *****141.74

TO THE ORDER OF
CENTRAL SANITARY SUPPLY
416 N 9TH ST STE A
MODESTO, CA 95360-5868



01160

Void After 180 DAYS.
Signature On File
This check has been authorized
by your depositor



⑈985003⑈ ⑆121100782⑆ 036438101⑈

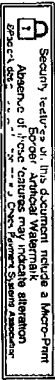
007759505

ENDORSE HERE

Central Sanitary Supply Co Inc
9444868

Oak Valley Community Bank
721442118

DO NOT WRITE STAMP OR SIGN BELOW THIS LINE
RESERVED FOR FINANCIAL INSTITUTION USE



Security feature of this document is a Micro-Print
Security feature of this document is a Micro-Print
Absence of these features may indicate alteration
© 2019 Federal Reserve System
* FEDERAL RESERVE BOARD OF GOVERNORS REG DC

DOCUMENT CONTAINS COLORED BACKGROUND ON WHITE PAPER. VOID FEATURE, SMALL ATFD WATERMARK (REVERSE SIDE), MICROPRINT BORDER.

Account: 18950

PLEASE POST THIS PAYMENT FOR OUR MUTUAL CUSTOMER

\$44.92

78/1211

Please Direct Any Questions To
(800) 243-2508
Online Bill Payment Processing Center

0000985004

September 06, 2019

CALWA RECREATION & PARK DISTRICT
4545 E CHURCH AVE
FRESNO, CA 93726-1537

BANK OF THE WEST

01150 3333661 002028 002028 00020007 1002027

MEMO: 1002378

DOLLARS

Pay FORTY FOUR AND 92/100

\$ *****44.92

TO CENTRAL SANITARY SUPPLY
THE 416 N 9TH ST STE A
ORDER MODESTO, CA 95350-5888
OF

Void After 180 DAYS.
Signature On File
This check has been authorized
by your depositor




⑈985004⑈ ⑆121600782⑆ 036438101⑈

007759504

ENDORSE HERE

X
Central Sanitary Supply Co Inc
3112888
Oak Valley Community Bank
121142119

DO NOT WRITE STAMP OR SIGN BELOW THIS LINE
RESERVED FOR FINANCIAL INSTITUTION USE

 Security features on this document include a Micro-Print border. Absence of these features may indicate a counterfeit document.
* FEDERAL RESERVE BOARD OF GOVERNORS REG CC

Account: 18950

PLEASE POST THIS PAYMENT FOR OUR MUTUAL CUSTOMER

\$63.54

78/1211

Please Direct Any Questions To
(800) 243-2608
Online Bill Payment Processing Center

000985005

September 06, 2019

CALWA RECREATION & PARK DISTRICT
4545 E CHURCH AVE
FRESNO, CA 93725-1637

BANK OF THE WEST

01150 3333961 002029 002029 00030007 0002028

MEMO: 1001877

DOLLARS

Pay SIXTY THREE AND 84/100

\$ *****63.54

TO CENTRAL SANITARY SUPPLY
THE 416 N 9TH ST STE A
ORDER MODESTO, CA 95350-5868
OF

VOID After 180 DAYS.
Signature On File
This check has been authorized
by your depositor



⑈985005⑈ ⑆121600782⑆ 036438101⑈

007759503

ENDORSE HERE

X
Central Sanitary Supply Co Inc
9415666

Oak Valley Community Bank
121542118

DO NOT WRITE STAMP OR SIGN BELOW THIS LINE
RESERVED FOR FINANCIAL INSTITUTION USE

Security features on this check will include a Micro-Print
Border. A Micro-Watermark.
Absence of these features may indicate alteration
of the check.
* FEDERAL RESERVE BOARD OF GOVERNORS REG CC

Account: **CALWA RECREATION & PARK DISTRICT** \$75.00

PLEASE POST THIS PAYMENT FOR OUR MUTUAL CUSTOMER



Please Direct Any Questions To
(800) 243-2508
Online Bill Payment Processing Center

78/1211

CALWA RECREATION & PARK DISTRICT
4545 E CHURCH AVE
FRESNO, CA 93725-7537

0000985010

September 17, 2019

MEMO: Invoice:101680

BANK OF THE WEST

12147 3304245 012148 012149 0001 0001 0012147

Pay SEVENTY FIVE AND 00/100

DOLLARS

TO THE ORDER OF
STREAMLINE
2321 P ST FL 1
SACRAMENTO, CA 95816-6280



12147

\$ *****75.00

Void After 180 DAYS.
Signature On File
This check has been authorized
by your depositor



⑈985010⑈ 1214700782⑈ 03648810⑈

0105088
RESERVED FOR FINANCIAL INSTITUTION USE
DO NOT WRITE STAMP OR SIGN BELOW THIS LINE
DIGITAL DEPLOYMENT IN
First Deposit Only
121471398
9/27/2019

Security features on this document include a Micro-Print border, Absence of frisk features and a watermark. For more information, visit www.frb.org.
* FEDERAL RESERVE BOARD OF GOVERNORS REG. CC

Account: 415887

PLEASE POST THIS PAYMENT FOR OUR MUTUAL CUSTOMER

\$82.97

78/1211

Please Direct Any Questions To
(800) 243-2508
Online Bill Payment Processing Center

0000985011

September 17, 2019

CALWA RECREATION & PARK DISTRICT
4545 E CHURCH AVE
FRESNO, CA 93725-1537

BANK OF THE WEST

02212 8782480 056021 056321 00130030 K056018

MEMO: invoice:64877797

DOLLARS

Pay EIGHTY TWO AND 97/100

\$ *****82.97

TO TFS LEASING/ DE LAGE LANDEN
THE PO BOX 41602
ORDER PHILADELPHIA, PA 19101-1602
OF

Void After 180 DAYS
Signature On File
This check has been authorized
by your depositor



⑈985011⑈ ⑆12100782⑆ 036438101⑈

611802094

ENDORSE HERE

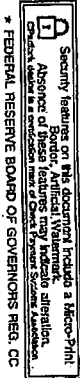
X

20190920

822597

DO NOT WRITE STAMP OR SIGN BELOW THIS LINE
RESERVED FOR FINANCIAL INSTITUTION USE

20190920
>031000053<
PNC bank
DEP. TO CR. PAYEE
ABS. OF END. GTD.
>031000053<



Security features on this document include a Micro-Print
Alphabet, a Hidden, Artificial Watermark, Ultraviolet
Color, and a color-coded line of numbers.
* FEDERAL RESERVE BOARD OF GOVERNORS REG. CC

Account: 156757-153810

PLEASE POST THIS PAYMENT FOR OUR MUTUAL CUSTOMER

\$7,679.48

Please Direct Any Questions To
(800) 243-2508
Online Bill Payment Processing Center

78/1211

0000985016

CALWA RECREATION & PARK DISTRICT
4545 E CHURCH AVE
FRESNO, CA 93726-1537

September 25, 2019

BANK OF THE WEST

02045 3393228 054159 054159 00220030 1054166

DOLLARS

Pay SEVEN THOUSAND SIX HUNDRED SEVENTY NINE AND 48/100

\$ *****7,679.48

TO CITY OF FRESNO
THE PO BOX 2069
ORDER FRESNO, CA 93718-2069
OF

Void After 180 DAYS.
Signature On File
This check has been authorized
by your depositor




⑈ 985016 ⑆ 12100782 ⑆ 03643810 1 ⑆

013073161

ENDORSE HERE
City of Fresno
acct number 1499610782

DO NOT WRITE STAMP OR SIGN BELOW THIS LINE
RESERVED FOR FINANCIAL INSTITUTION USE

 Security features of this document include a Micro-Print
Border. Authentic Watermark.
Absence of these features may indicate alteration.
For more information, visit www.fresno.gov
* FEDERAL RESERVE BOARD OF GOVERNORS REG. CC

Reconciliation Summary

Fresno County Account, Period Ending 09/30/2019

	<u>Sep 30, 19</u>
Beginning Balance	161,805.74
Cleared Transactions	
Deposits and Credits - 1 item	2,121.81
Total Cleared Transactions	<u>2,121.81</u>
Cleared Balance	<u>163,927.55</u>
Register Balance as of 09/30/2019	163,927.55
New Transactions	<u>-39,058.57</u>
Ending Balance	<u><u>124,868.98</u></u>

Reconciliation Detail

Fresno County Account, Period Ending 09/30/2019

Type	Date	Num	Name	Clr	Amount	Balance
Beginning Balance						161,805.74
Cleared Transactions						
Deposits and Credits - 1 item						
Deposit	09/30/2019			X	2,121.81	2,121.81
Total Deposits and Credits					2,121.81	2,121.81
Total Cleared Transactions					2,121.81	2,121.81
Cleared Balance					2,121.81	163,927.55
Register Balance as of 09/30/2019					2,121.81	163,927.55
New Transactions						
Checks and Payments - 9 items						
Check	10/04/2019	65-0284903	Calwa Recreation and Park District		-20,000.00	-20,000.00
Check	10/04/2019	65-0284904	Calwa Recreation and Park District		-10,379.67	-30,379.67
Check	10/04/2019	65-0284906	Calwa Recreation and Park District		-7,899.83	-38,279.50
Check	10/04/2019	65-0284912	Central Sanitary Supply		-336.54	-38,616.04
Check	10/04/2019	65-0284907	Hilda Galaviz		-250.00	-38,866.04
Check	10/04/2019	65-0284905	KS StateBank		-162.53	-39,028.57
Check	10/04/2019	65-0284910	Blanca Parra		-10.00	-39,038.57
Check	10/04/2019	65-0284908	Brenda Malicder		-10.00	-39,048.57
Check	10/04/2019	65-0284909	Laura Salvatierra		-10.00	-39,058.57
Total Checks and Payments					-39,058.57	-39,058.57
Deposits and Credits - 1 item						
Check	10/07/2019	650284913	Calwa Recreation and Park District		0.00	0.00
Total Deposits and Credits					0.00	0.00
Total New Transactions					-39,058.57	-39,058.57
Ending Balance					-36,936.76	124,868.98

Report ID: GISF9100
 Program: GISF9100

PeopleSoft
 MONTHLY GENERAL LEDGER TRANSACTION REGISTER
 Journal Dates 09/01/2019 through 09/30/2019

Page No. 1
 Run Date 10/02/2019
 Run Time 14:59:46

Fund: 4660 Calwa Park And Recreation Dist SUBCLASS: 10000 ACCOUNT: 0110

Journal Date	Jrnl Src	Jrnl ID	Header Description	Line Ref	Debit Amount	Credit Amount
Subclass: 10000 General Subclass						
Beginning Balance					161,805.74	
09/04/2019	AUD	0001882111	20 - PRIOR UNSECURED 1ST 1 PU 1ST		193.19	
09/10/2019	AUD	0001882801	20 - CURRENT SECURED SUPPL CSSI		572.08	
09/16/2019	AUD	0001883786	4th QTR- 2nd INT DISTB		1,356.54	
Cash In Treasury					2,121.81	
Ending Balance					163,927.55	0.00
Account: 0315					1,356.54	1,356.54
Beginning Balance						
09/16/2019	ALO	0001883788	4th QTR- To reverse 2nd IN			
Interest Receivable					0.00	1,356.54
Ending Balance						
Account: 3011					0.00	572.08
Beginning Balance						
09/10/2019	AUD	0001882801	20 - CURRENT SECURED SUPPL CSSI			
Suppl-Current Secured					-2,872.68	572.08
Ending Balance						
Account: 3025					0.00	193.19
Beginning Balance						
09/04/2019	AUD	0001882111	20 - PRIOR UNSECURED 1ST 1 PU 1ST			
Property Taxes-Prior Unsecured					-193.19	193.19
Ending Balance						
Account: 3380					1,356.54	1,356.54
Beginning Balance						
09/16/2019	ALO	0001883786	4th QTR- 2nd INT DISTB			
09/16/2019	ALO	0001883788	4th QTR- To reverse 2nd IN			
Interest					1,356.54	1,356.54
Ending Balance					0.00	
Subclass Total					3,478.35	3,478.35
Fund Total					3,478.35	3,478.35

End of Report

Report ID: GLSF9109
 Program: GLSF9109

PeopleSoft
 MONTHLY GENERAL LEDGER TRIAL BALANCE

Fiscal Year 2020
 Through Period 3

Page No. 1
 Run Date 10/02/2019
 Run Time 14:59:46

Fund:	4660	Calwa Park And Recreation Dist	Debit Accts	Beginning Balance	Credit Accts	Year-to-Date	Transaction	Current	Balances
Subclass:	10000	General Subclass				Debits	Credits	Accts	Credit Accts
0110	Cash In Treasury		279,610.17	0.00	0.00	0.00	115,682.62	163,927.55	0.00
0315	Interest Receivable		1,460.13	0.00	0.00	0.00	1,460.13	0.00	0.00
1435	Due To Other Governmental		0.00	1,619,309.92	0.00	0.00	0.00	0.00	1,619,309.92
1480	Fiduciary Closing		0.00	1,341,672.42	0.00	0.00	0.00	0.00	1,341,672.42
2230	Fund Balance - Unassigned		0.00	-2,679,912.04	120,208.62	0.00	2,872.68	0.00	-2,800,120.66
3011	Suppl-Current Secured		0.00	0.00	0.00	0.00	193.19	0.00	2,872.68
3025	Property Taxes-Prior Unsec		0.00	0.00	0.00	0.00	0.00	0.00	193.19
3380	Interest		0.00	0.00	0.00	0.00	0.00	0.00	0.00
	SUB CLASS TOTAL		281,070.30	281,070.30	120,208.62	120,208.62	163,927.55	163,927.55	163,927.55

End of Report

Report ID: GLSF9109
Program: GLSF9109

Peoplesoft
MONTHLY GENERAL LEDGER TRIAL BALANCE

Fiscal Year 2020
Through Period 3

Page No. 2
Run Date 10/02/2019
Run Time 14:59:46

Fund: 4660
Calwa Park And Recreation Dist
Subclass: 10000
General Subclass

	Beginning Balance Debit Accts	Credit Accts	Year-to-Date Debits	Transaction Credits	Current Balances Debits Accts	Credit Accts
GRAND TOTALS	281,070.30	281,070.30	120,208.62	120,208.62	163,927.55	163,927.55

End of Report

Reconciliation Summary

Bank of the West Payroll, Period Ending 09/30/2019

	<u>Sep 30, 19</u>
Beginning Balance	47,876.55
Cleared Transactions	
Checks and Payments - 12 items	-18,484.68
Deposits and Credits - 2 items	117.36
Total Cleared Transactions	<u>-18,367.32</u>
Cleared Balance	<u>29,509.23</u>
Register Balance as of 09/30/2019	29,509.23
New Transactions	<u>18,279.50</u>
Ending Balance	<u><u>47,788.73</u></u>

Reconciliation Detail

Bank of the West Payroll, Period Ending 09/30/2019

Type	Date	Num	Name	Clr	Amount	Balance
Beginning Balance						47,876.55
Cleared Transactions						
Checks and Payments - 12 items						
Check	08/30/2019	985019	Aflac Health	X	-117.36	-117.36
Check	09/03/2019	11023	Bobby D Otero	X	-1,086.80	-1,204.16
Check	09/03/2019	11022	Gabriela Mares	X	-456.75	-1,660.91
Check	09/03/2019	11021	Raul Guerra	X	-340.02	-2,000.93
Check	09/03/2019	11024	Esmeralda Zamora	X	-340.02	-2,340.95
Check	09/04/2019	DEBIT	ADP	X	-5,748.61	-8,089.56
Check	09/04/2019	DEBIT	ADP	X	-2,342.99	-10,432.55
Check	09/13/2019	DEBIT	ADP	X	-80.40	-10,512.95
Check	09/17/2019	DEBIT	ADP	X	-5,130.68	-15,643.63
Check	09/17/2019	DEBIT	ADP	X	-1,767.37	-17,411.00
Check	09/17/2019	11025	Bobby D Otero	X	-1,001.78	-18,412.78
Check	09/27/2019	DEBIT	ADP	X	-71.90	-18,484.68
Total Checks and Payments					-18,484.68	-18,484.68
Deposits and Credits - 2 items						
Deposit	09/04/2019			X	58.68	58.68
Deposit	09/17/2019			X	58.68	117.36
Total Deposits and Credits					117.36	117.36
Total Cleared Transactions					-18,367.32	-18,367.32
Cleared Balance					-18,367.32	29,509.23
Register Balance as of 09/30/2019					-18,367.32	29,509.23
New Transactions						
Deposits and Credits - 2 Items						
Check	10/04/2019	65-0284906	Calwa Recreation and Park D...		7,899.83	7,899.83
Check	10/04/2019	65-0284904	Calwa Recreation and Park D...		10,379.67	18,279.50
Total Deposits and Credits					18,279.50	18,279.50
Total New Transactions					18,279.50	18,279.50
Ending Balance					-87.82	47,788.73



BANK OF THE WEST
BNP PARIBAS

P.O. Box 2830, Omaha, NE 68103-2830

Account Statement

September 1, 2019 - September 30, 2019

Page 1 of 6

CALWA RECREATION & PARK DISTRICT
 4545 E CHURCH AVE
 FRESNO CA 93725-1537

At your service



bankofthewest.com



1-800-488-2265



1-800-659-5495 TTY/TDD

New online and mobile services!

Enjoy these new online card services: Online statements - Online and recurring payments - Dispute transactions - Travel notices - PIN change - Account alerts - Replacement cards - Card activation - Lock/unlock your card.

Simply log into your account at www.bankofthewest.com and go to the Services and Support page or on your mobile device on the More screen.

Remember to confirm your email during your next branch visit or call our Contact Center at 800-488-2265. Our emails keep you educated about our services, products and more.

REGULAR BUSINESS CHECKING

CALWA RECREATION & PARK DISTRICT

ACCOUNT SUMMARY

Beginning Balance	\$47,876.55
6 Credits	117.36
0 Deposits	0.00
6 Withdrawals	-15,141.95
6 Checks	-3,342.73
Ending Balance	\$29,509.23

EARNINGS SUMMARY

Interest this statement period	\$0.00
Interest credited year-to-date	\$0.00
Annual percentage yield earned	0.00%
Average monthly balance	\$35,341.65

For your protection:

Examine this statement promptly. Any discrepancy must be reported within 30 days. Consumer customers: A discrepancy regarding an electronic payment or line of credit must be reported within 60 days.

In South Dakota, Bank of the West operates under the name of Bank of the West California.





REGULAR BUSINESS CHECKING

(continued)

ACCOUNT DETAIL

Credits

<i>Date</i>	<i>Amount</i>	<i>Description</i>
09/04	\$12.42	ELECTRONIC DEP CALWA RECREATION DIRECT DEP 090419PPD
09/04	16.32	ELECTRONIC DEP CALWA RECREATION DIRECT DEP 090419PPD
09/04	29.94	ELECTRONIC DEP CALWA RECREATION DIRECT DEP 090419PPD
09/17	12.42	ELECTRONIC DEP CALWA RECREATION DIRECT DEP 091719PPD
09/17	16.32	ELECTRONIC DEP CALWA RECREATION DIRECT DEP 091719PPD
09/17	29.94	ELECTRONIC DEP CALWA RECREATION DIRECT DEP 091719PPD

6 credits for a total of \$117.36

Withdrawals

<i>Date</i>	<i>Amount</i>	<i>Description</i>
09/04	\$2,342.99	ELECTRONIC DBT ADP Tax ADP Tax 090419 RRJIG 090318A01 CCD
09/04	5,748.61	ELECTRONIC DBT ADP WAGE PAY WAGE PAY 090419 686080017442JIG CCD
09/13	80.40	ELECTRONIC DBT ADP PAYROLL FEES ADP - FEES 091319 2RJIG 2787238 CCD
09/17	1,767.37	ELECTRONIC DBT ADP Tax ADP Tax 091719 RRJIG 091719A01 CCD
09/17	5,130.68	ELECTRONIC DBT ADP WAGE PAY WAGE PAY 091719 726074448594JIG CCD
09/27	71.90	ELECTRONIC DBT ADP PAYROLL FEES ADP - FEES 092719 2RJIG 6293424 CCD

6 withdrawals for a total of \$15,141.95

Checks Paid

<i>Number</i>	<i>Date paid</i>	<i>Amount</i>	<i>Number</i>	<i>Date paid</i>	<i>Amount</i>	<i>Number</i>	<i>Date paid</i>	<i>Amount</i>
11021	09/30	340.02	11023	09/04	1,086.80	11025	09/17	1,001.78
11022	09/06	456.75	11024	09/19	340.02	985019*	09/10	117.36

6 checks paid for a total of \$3,342.73

* Break in check number sequence.





IMPORTANT INFORMATION

IN CASE OF ERRORS OR QUESTIONS ABOUT YOUR ELECTRONIC TRANSFERS (For accounts that are maintained primarily for personal, family or household purposes.)



Telephone us at (800) 488-2265, or write us at Bank of the West*, Branch Service Center, P.O. Box 2573, Omaha, NE 68103-2573 as soon as you can if you think your statement or receipt is wrong or if you need more information about a transfer listed on the statement or receipt. We must hear from you no later than 60 days after we sent you the FIRST statement on which the error or problem appeared. We will need to know the following:

1. Tell us your name and account number (if any).
2. Describe the error or the transfer you are unsure about, and explain as clearly as you can why you believe it is an error or why you need more information.
3. Tell us the dollar amount of the suspected error.

We will investigate your complaint and will correct any error promptly. If we take more than 10 business days (20 business days for transactions involving new accounts) to do this, we will credit your account for the amount you think is in error, so that you will have the use of the money during the time it takes us to complete our investigation.

00773 3427894 001542 003083 0002/0003

*In South Dakota, Bank of the West operates under the name of Bank of the West California.





BANK OF THE WEST
BNP PARIBAS

Account Statement

September 1, 2019 - September 30, 2019

Page 4 of 6

This space intentionally left blank.



bankofthewest.com



1-800-488-2265



1-800-659-5495 TTY/TDD



BANK OF THE WEST
BNP PARIBAS

Account Statement

September 1, 2019 - September 30, 2019

Page 6 of 6

This space intentionally left blank.



bankofthewest.com

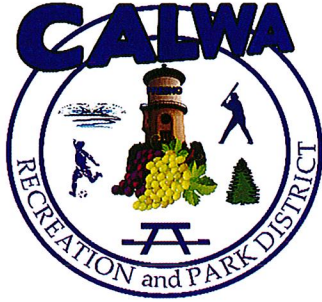


1-800-488-2265



1-800-659-5495 TTY/TDD

**Calwa Recreation and Park District
Agenda Item Transmittal**



Meeting Date: October 15, 2019

Agenda Item Number: G-1

Wording for Agenda: Update on the Swimming Pool Construction.

Submitting: District Administrator

Contact Name and Phone Number: Felix Ortiz
559-264-6867

Department Recommendation: No recommendation

Summary/Background:

The Calwa Pool project plans were completed by the engineers in mid-September and CIII Constriction, Lou Bossi, submitted the plans to the Fresno County Environmental Health Department for review and approval.

Environmental Health returned the plans for some additional information regarding the restrooms and showers. The plans are currently being updated to address these requests from Environmental Health. The updated plans are scheduled to be submitted the week of October 7, 2019.

As it stands, CIII Construction has scheduled the project work to begin the week of October 21, 2019. With that said, our office would like to work with the Park staff and Board on a groundbreaking ceremony that same week.

Prior Board Actions: Approved moving forward with construction of swimming pool.

Attachments: Items that need correction or are missing from submitted plans. (Dept. of Public Health).

Recommended motion to be made by Board: None. Information only.

For action by:

District Board

Regular Session:

Consent Calendar

Regular Item

Public Hearing

Review:

**District Administrator
(Initials Required)**



County of Fresno
DEPARTMENT OF PUBLIC HEALTH
Environmental Health Division

September 20, 2019

FA0002964
PR0010052
PE3624

C-III Construction, Inc.
Attn: Louis Brosi
P.O. Box 27381
Fresno, CA 93729

Dear Mr. Brosi:

SUBJECT: Public Swimming Pool
LOCATION: Calwa Park, 4545 E. Church Avenue, Fresno

The plans have been reviewed for the above project. The following items need correction or are missing from the submitted plans. Correct the following and resubmit for further review:

1. Provide plans and specifications for the proposed pool user restrooms and drinking fountains. [California Building Code (CBC) Sections 3116B & 3117B]
2. Correct the existing shower locations that are shown on the plans, see sheets A1, A2, and A3. Existing showers are located adjacent to the South East entrance area along the East enclosure fence. (CBC Section 3116B)
3. Provide adequate decking to access the existing showers; decking in this area is shown to be removed. See sheet A2. (CBC Section 3116B)
4. Clarify the hot water heater location for the existing showers. (CBC Section 3116B)
5. Correct keynote 1 locations shown on sheet A3. (CBC Section 3119B)
6. Correct the fence/enclosure note on sheet A1 as this conflicts with keynote 1 on sheets A2 and A3. (CBC Section 3119B)
7. Provide for any proposed doors from the existing building. Doors opening into the pool enclosure shall be self-closing and self-latching and shall be provided with door opening hardware between 42-44-inches measured from the deck or walkway. (CBC Section 3119B)
8. Locate the "Keep Gate Closed" signs on the exterior side on each gate. Correct keynote 16 language and the shown locations on sheet A3. (CBC Section 3120B)
9. If doors are proposed from the existing building into the pool enclosure, provide approved "Keep Door Closed" signs on each door. (CBC Section 3120B)

Promotion, preservation and protection of the community's health

1221 Fulton Street /P. O. Box 11867, Fresno, CA 93775

(559) 600-3357 • FAX (559) 600-7629

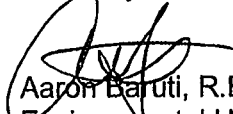
The County of Fresno is an Equal Employment Opportunity Employer

www.co.fresno.ca.us • www.fcdph.org

10. Provide an enclosure/fence for the pool equipment area so that access is limited to persons authorized by the pool owner or operator. (CBC Section 3122B)
11. Provide a floor drain inside the pool equipment area; slope floor minimum ¼-inch per foot to the drain. (CBC Section 3122B)
12. Clarify the type of deck drainage system proposed to prevent standing water around the West, North, and East deck areas. Proposed landscape is unclear for these areas. (CBC Section 3114B)
13. Provide a second set of safety equipment (life-ring/rope and pole/body hook) on opposing sides at centralized locations. This is required for pools exceeding 75 feet in length. (CCR Section 65540)
14. Provide a minimum 3-inch return line size to first floor return branch for Groups #1 and #3. (CBC Section 3125B)
15. Correct the pump quantity number on detail 38/D4. (CBC Section 3123B)

After the above corrections are made, please resubmit the revised sets of drawings to 1221 Fulton Street, 3rd Floor, Fresno, CA 93721. I may be reached at (559) 600-3357 if you have any questions.

Sincerely,

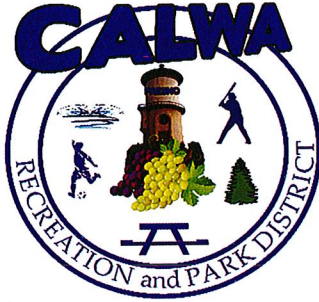


Aaron Baruti, R.E.H.S.
Environmental Health Specialist
Environmental Health Division

AB/slk

c: Calwa Park & Recreation District, 4545 E. Church Avenue, Fresno, CA 93725

Calwa Recreation and Park District Agenda Item Transmittal



Meeting Date: October 15, 2019

Agenda Item Number: H-1

Wording for Agenda: Review the Possibility of Retrofit for all Soccer Field Lights.

Submitting: District Administrator

Contact Name and Phone Number: Felix Ortiz
559-264-6867

Department Recommendation: No recommendation

Summary/Background:

By retrofitting the Calwa Recreation and Park District Soccer Lights, the District will reduce usage by approximately 75,160 kWh annually. This translates to approximately \$11,334 in annual savings. In addition to saving money, the fields will be brighter, safer, and more evenly illuminated.

Prior Board Actions:

Attachments: Executive Summary

Recommended motion to be made by Board: None. Information only.

For action by:

District Board

Regular Session:

Consent Calendar

Regular Item

Public Hearing

Review:

**District Administrator
(Initials Required)**

Executive Summary

Calwa Recreation & Park District
September 30, 2019

Option 1, Primary Technology: LED, CA Based



Overall System Investment

Material Cost	Included
Labor Cost	Included
Recycling of Existing Fixtures in Accordance w/ CA Law	Included
Scissor and/or Boom Lift Rental	Included
System Design	Included
Project Management	Included
Rebate Administration and Acceptance as Payment*	Not Included
Surge Suppression	Not Included
Shipping	Included
Other Energy Conservations Measures (ECMs)	Not Included

Gross Investment	\$105,707
Less Rebate (Utility and/or Manufacturer)	\$0
Net Investment	\$105,707
Sales Tax (estimated)	\$7,558
Total	\$113,265

Profit from Upgrade

Annual Electrical Waste Reduction: Lighting & Controls	\$11,275
Annual Electrical Waste Reduction: HVAC, Source: R. Rundq	\$0
Annual Maintenance Savings	\$59
Rebate: Manufacturer/Instant (Expiration dates may apply, sub	\$0
Rebate: Utility Company (Subject to application and approval)	\$0

1st Year Profit from Upgrade **\$11,334**

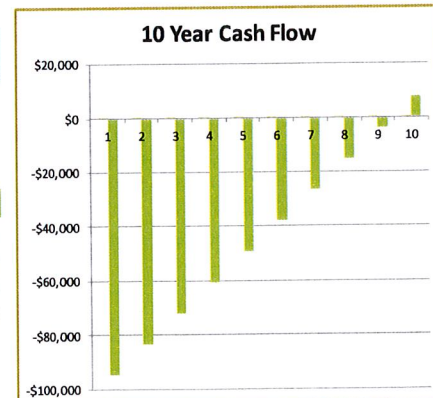
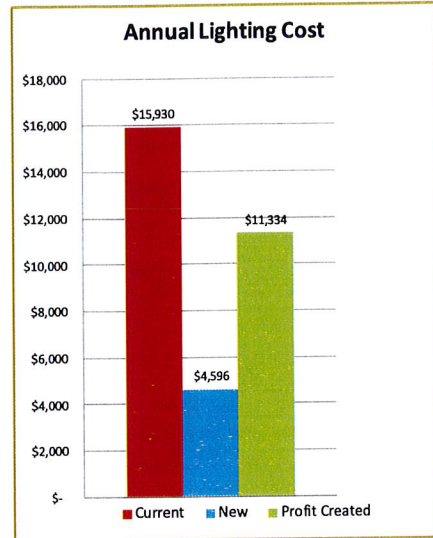
Projected Annual Profit from Upgrade \$11,334
Average Monthly Profit from Upgrade \$944
Annual Kilowatt Hours Reduced 75,163
Demand Reduction, kW -

Financial Metrics

	Important	Dates
Return On Investment (ROI)	11%	9/25/23
Breakeven Period in Months	56.0	5/25/28
Payback Period in Months	111.9	5/25/28

10 Year Cash Flow

Year 1	(\$94,374)	Year 6	(\$37,706)
Year 2	(\$83,040)	Year 7	(\$26,372)
Year 3	(\$71,706)	Year 8	(\$15,039)
Year 4	(\$60,373)	Year 9	(\$3,705)
Year 5	(\$49,039)	Year 10	\$7,628



Lead Time: 4-5 Weeks or Less (Standard Products) Proposal Valid for 60 Days

OPTIONS (Check C)

I Would Like to use Purchase Order #: _____
 I Would Like to Pay by Credit Card (check here) _____
 I Would Like a Free Cash Flow Agreement (check here) _____

Terms: **50% On Order, Balance on Completion**

Accepted By (print): _____ Date: _____

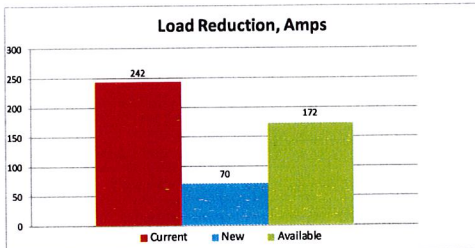
Signature: _____

TF

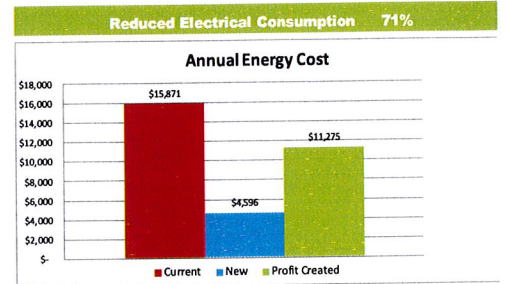
PLEASE EMAIL ACCEPTANCE TO tom@truenorthled.com

Project Data by Facility Area

#	Facility Area Description	Voltage	EXISTING				New Fixture or Retrofit	PROPOSED				ENERGY SAVINGS				ANNUAL SAVINGS				
			Qty	Fixture	Watts	Annual Hours		KeVn	Warr Years	Qty	Watts	Annual Hours	Existing Annual kWh	Lighting kWh Saved	Controls Savings		Controls kWh Saved	Total kWh Saved	kW (demand) Saved	
1	S Field	480	20	1000w MH	1080	912	New	Linmore Site Lighter 300w HV + Surge Sup	5000	10	20	300	912	19,699	14,227	0	0	14,227	15.60	\$ 2,134
2	NW Field	480	33	1000w MH	1080	912	New	Linmore Site Lighter 300w HV + Surge Sup	5000	10	33	300	912	32,504	23,475	0	0	23,475	25.74	\$ 3,521
3	NE Field	480	47	1000w MH	1080	912	New	Linmore Site Lighter 300w HV + Surge Sup	5000	10	47	300	912	46,293	33,434	0	0	33,434	36.66	\$ 5,015
4	SW Field	480	6	1000w MH	1080	912	New	Linmore Site Lighter 300w HV + Surge Sup	5000	10	6	300	912	5,910	4,268	0	0	4,268	4.68	\$ 640
5	Basketball	480	12	100w MH	128	912	New	Linmore Site Lighter 150w HV + Surge Sup	5000	10	12	150	912	1,401	-241	0	0	-241	-0.28	\$ [36
			118				Totals:				118				105,807	75,163	0	75,163	82.42	\$ 11,275

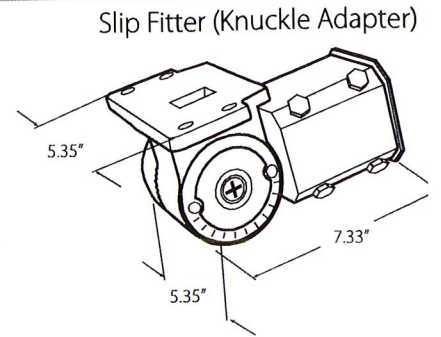
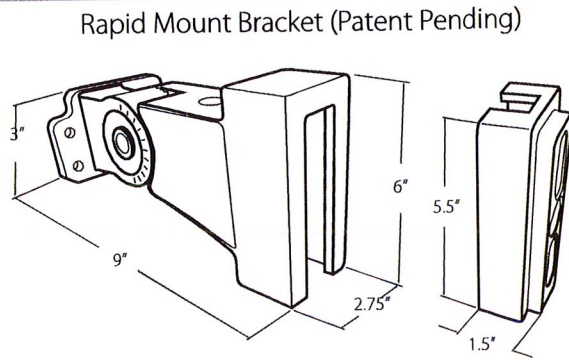
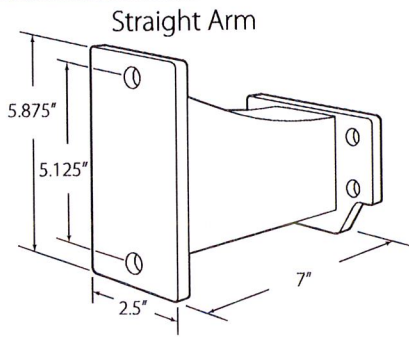


*Chart Data for Facility Areas on this Page Only

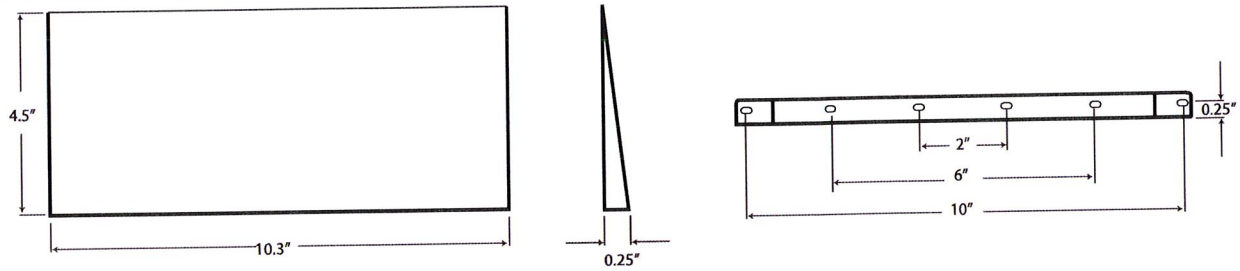


*Chart Data for Facility Areas on this Page Only

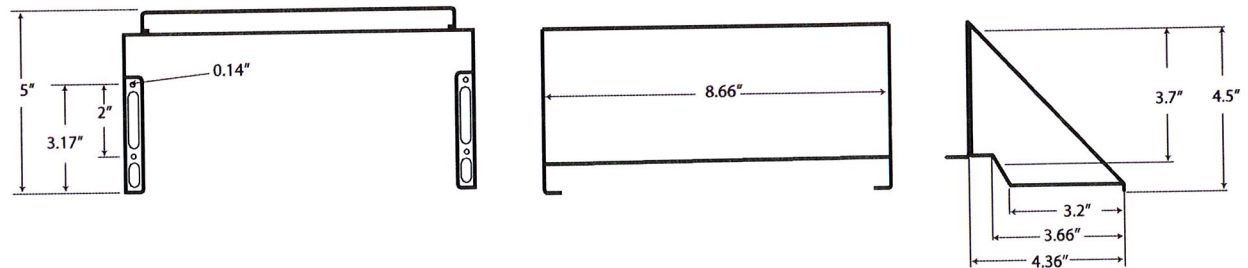
SITE LIGHTER (SL1)



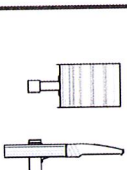
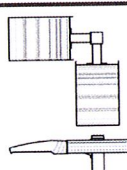
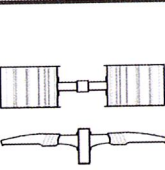
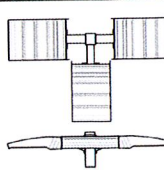
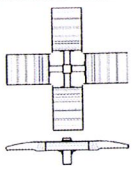
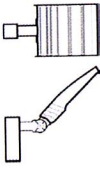
Glare Shield - Side



Glare Shield - Back



EPA Calculation

Wattage						
50W	0.61	0.88	1.22	1.24	1.24	0.46
75W	0.61	0.88	1.22	1.24	1.24	0.46
100W	0.61	0.88	1.22	1.24	1.24	0.46
125W	0.61	0.88	1.22	1.24	1.24	0.46
150W	0.61	0.88	1.22	1.24	1.24	0.46
200W	0.61	0.92	1.22	1.24	1.24	0.46
300W	0.61	0.97	1.22	1.24	1.24	0.46
400W	0.61	0.97	1.22	1.24	1.24	0.46

Specifications are Subject to Change.

SITE LIGHTER (SL1)

System Components

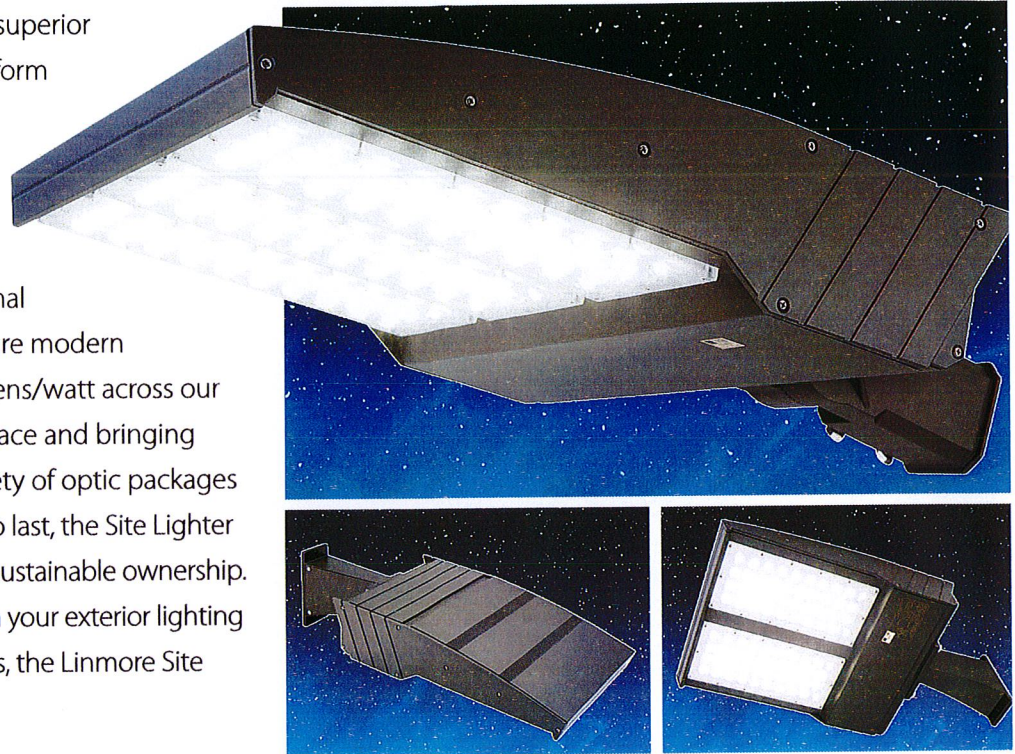
T2	Type 2 Optics
T3	Type 3 Optics
T4	Type 4 Optics
T5	Type 5 Optics
FR-L	Front Row Optics
FR-R	Front Row Optics
FL35	Flood Optics 35 Degrees
FL60	Flood Optics 60 Degrees
LL-SL1-SM-GSB	Site Lighter Glare Shield Back for use with Small Chassis (50-100w)
LL-SL1-MD-GSB	Site Lighter Glare Shield Back for use with Medium Chassis (125-200w)
LL-SL1-LG-GSB	Site Lighter Glare Shield Back for use with Large Chassis (300w)
LL-SL1-XL-GSB	Site Lighter Glare Shield Back for use with Extra Large Chassis (400w)
LL-SL2-ALL-GSS	Side Lighter Glare Shield Side for use with All Models, each
HV1	High Voltage Driver, 200-480 Volt, for SL1 Fixtures up to 200 Watts, adder
HV2	High Voltage Driver, 200-480 Volt, for SL1 Fixtures over 201 Watts, adder
SPD-277P-20KA-EC1	20ka Surge Suppressor
PC-UNV	Photocell, Button, Mounted in Side Plate, 120-277 Volt
PC-480V	Photocell, Twist Lock, 480 Volt
LL-SL1-RMB	Rapid Mount Bracket
LL-SL1-SA	Straight Arm Bracket
LL-SL1-SF	Slip Fitter Bracket
LL-SL1-TM	Trunion Mount Bracket
LL-SL1-A1	Vertical or Horizontal Mount for Flat Surfaces
LL-SL1-A2	Horizontal Mount for Round Poles
LL-SL1-A3	Horizontal Wall Mount
LL-SL1-A4	Vertical Wall Mount
LL-SL1-A10	Single Fixture Multi-Mount Bracket
LL-SL1-A12	Round to Square Pole Adapter
LL-SL1-A5	Square to Vertical Slip Fitter Adapter for 4" Square Pole
LL-SL1-A6	Square to Vertical Slip Fitter Adapter for 5" Square Pole
LL-SL1-A18	Square to Vertical Slip Fitter Adapter for 6" Square Pole
LL-SL1-A7	Round Pole to Slip Fitter Adapter for 4" Round Pole
LL-SL1-A14	Round Pole to Slip Fitter Adapter for 3" Round Pole
LL-SL1-A17	Slip Fitter Adapter for 4"-5" Square Poles
LL-SL1-A8	Two Fixture Bullhorn
LL-SL1-A9	Three Fixture Y Tenon
LL-SL1-A11	Three Fixture Straight Tenon
LL-SL1-A13	Four Fixture Straight Tenon
LL-SL1-A15	Three Fixture T Tenon
LL-SL1-A16	Two Fixture L Tenon

A detailed Exterior Application Guide can be found at linmoreled.com/pdfs/Exterior-Application-Guide.pdf



SITE LIGHTER (SL1)

Linmore LED Labs Site Lighter (SL1) is a superior combination of performance, value, and form factor. The body of the Site Lighter is unique in that it is extruded aluminum and exceptional at moving thermal energy while the rest of the market uses castings or weldments. Beyond the thermal efficiency of the housing, the aesthetics are modern and attractive. Efficacy averages 165 lumens/watt across our models putting the Site Lighter in rare space and bringing ultra-low wattages to site lighting. A variety of optic packages direct the light where it is needed. Built to last, the Site Lighter incorporates Linmore's drivers for years of sustainable ownership. When the objective is to maximize value in your exterior lighting with power, energy savings, and aesthetics, the Linmore Site Lighter is the clear choice.



HIGHLIGHTS

Optics:

Full Cut-Off
Type 2, Type 3, Type 4 & Type 5
Clear, Polycarbonate Lens
Glare Shields

Efficacy:

Ultra-High Efficacy-Up to 183 Lumens per Watt
Industry Leading

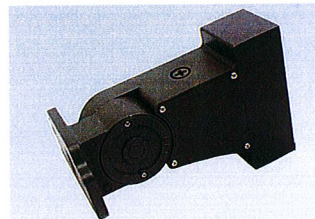
Construction:

Extruded Aluminum Body
Heavy Duty Powder Coating
Modern Form Factor

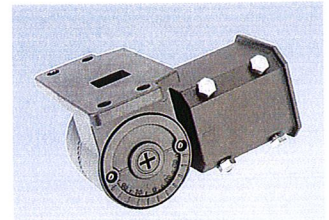
Controls/Sensors:

Linmore LED Driver 0-10V Dimming
Motion/Dimming Sensor
Photo Cell

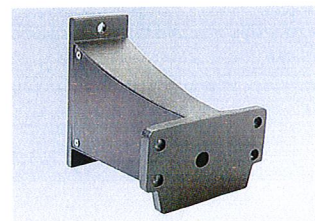
Bracket Options:



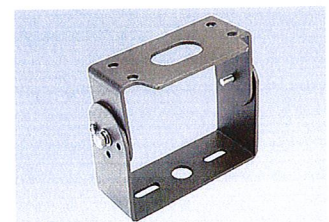
Rapid Mount Bracket
(Patent Pending)



Slip Fitter
(Knuckle Adapter)



Straight Arm



Trunnion (Yoke) Bracket

SITE LIGHTER (SL1)

Specifications

Suitability	Wet Locations-IP65 Rated
Warranty	10 Years
Expected Life	L70- 150,000 Hours
System Wattages	50W, 75W, 100W, 125W, 150W, 200W & 300W, 400W
Color Rendering Index (CRI)	>70
Color Temperature	2200K, 3500K, 4000K & 5000K

Operating Temperature	-40F to +130F
Efficacy	(5000K) Up to 183 Lumens/Watt
Voltage	120-277V, 200-480V
Certifications	UL 1598, FCC CFR 47, Part 15, ROHS, CUL Canada, BAA/TAA Compliant, ANSI C136.31-2010 "ANS for Roadway and Area Lighting Equipment - Luminaire Vibration"
Design Lights Consortium	Yes

Ordering Information

Model	Housing Size	Wattage	Kelvin	Optic	Volts	Housing Color	Mounting	Options
LL-SL1-	Small (SM)	50	2200K (22K)	Type 2 (T2)	120-277V (UNV)	Bronze (BRN)	Slip Fitter (SF)	FSP-201 (SN)
	Medium (MD)	75	3500K (35K)	Type 3 (T3)	200-480V (HV)	White (WHT)	Standard Arm (SA)	Photo Cell (PC)
	Large (LG)	100	4000K (40K)	Type 4 (T4)		Black (BLK)	Trunnion (TM)	
	Extra Large (XL)	125	5000K (50K)	Type 5 (T5)		Custom (CUS)*	Slip Fitter/ Knuckle Adapter (SF)	
		150		Flood (60)				
		200						
300								
400								

* Special Order

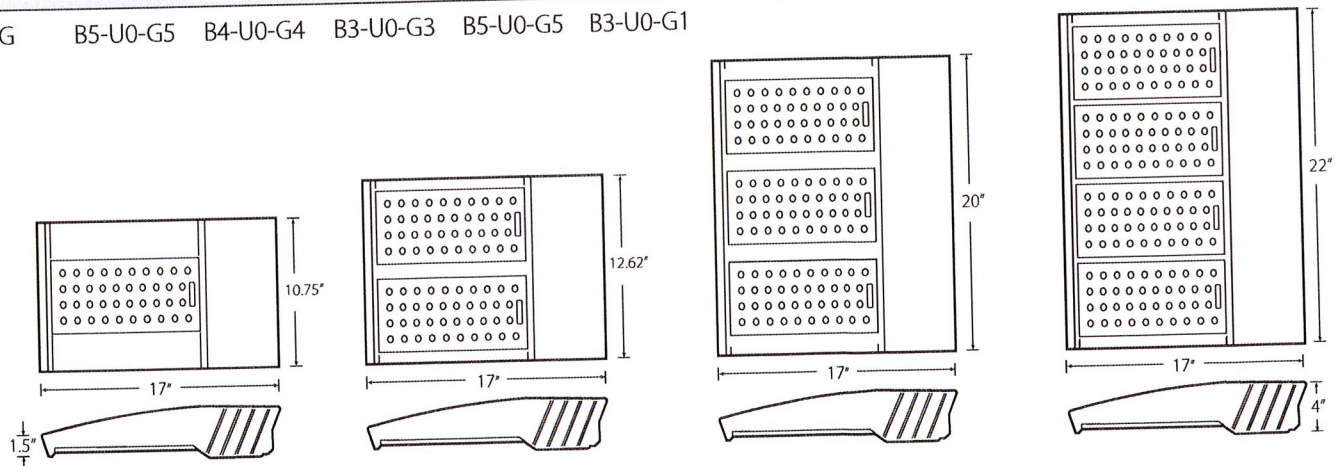
Example

LL-SL1-SM-75WD-50K-T2-UNV-BRN-SF-SN

Lumen Packages

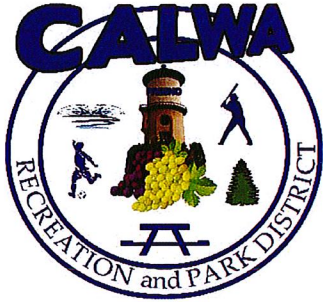
	T2	T3	T4	T5	60	Housing Type	Size (WxLxH)	Weight
50W	9897	9838	9611	9516	7000	Small	10.75 x 17 x 4 (taper to 1.5)	14
75W	13104	13026	12636	12558	10500	Small	10.75 x 17 x 4 (taper to 1.5)	14
100W	16224	16126	15600	16175	14000	Small	10.75 x 17 x 4 (taper to 1.5)	14
125W	21710	21493	20930	21645	17250	Medium	12.62 x 17 x 4 (taper to 1.5)	16
150W	25272	25019	24382	25196	20700	Medium	12.62 x 17 x 4 (taper to 1.5)	16
200W	30923	30745	32240	29648	26800	Medium	12.62 x 17 x 4 (taper to 1.5)	16
300W	47424	46950	45552	47282	40200	Large	20 x 17 x 4 (taper to 1.5)	24
400W	61000	61000	64000	59500	52000	Extra Large	22 x 17 x 4 (taper to 1.5)	37

BUG B5-U0-G5 B4-U0-G4 B3-U0-G3 B5-U0-G5 B3-U0-G1



Specifications are Subject to Change.

**Calwa Recreation and Park District
Agenda Item Transmittal**



Meeting Date: October 15, 2019

Agenda Item Number: H-2

Wording for Agenda: Consider Potential Facilities Fees Increase and Direction to Staff .

Submitting: District Administrator

Contact Name and Phone Number: Felix Ortiz
559-264-6867

Department Recommendation: Direction to Staff on Potential New Resolution Approving Increased Fees for Use of District Facilities and Park.

Summary/Background:

After a year of review, staff felt that the fees being charged was not enough and would like to increase the fees. I would like suggestions from the Board.

Prior Board Actions:

Attachments: Resolution 2019-__ with Exhibit A

Recommended motion to be made by Board: Move Direction to Staff on Potential New Resolution Approving Increased Fees for Use of District Facilities and Park.

For action by:

District Board

Regular Session:

Consent Calendar

Regular Item

Public Hearing

Review:

**District Administrator
(Initials Required)**

RESOLUTION NO. 2018-6

RESOLUTION OF THE BOARD OF DIRECTORS OF THE CALWA RECREATION AND PARK DISTRICT APPROVING FEES FOR USE OF DISTRICT FACILITIES AND PARK

WHEREAS, the Board of Directors has adopted reasonable fees for the use of District facilities and parks; and

WHEREAS, the Board of Directors has determined that the District facilities and park fees be amended to reflect the reasonable cost of providing the services and to allow for affordability; and

WHEREAS, after review and consideration, it is deemed by the Board of Directors that it is in the best interest of the District and its residents that certain fees be adjusted.

NOW, THEREFORE, the Board of Directors of the Calwa Recreation and Park District / resolves as follows:

Section 1. The foregoing recitals are true and correct and are incorporated by reference.

Section 2. The Board approves the Calwa District Facilities and Park Fees schedule attached as Exhibit A.

Section 3. District staff is directed to take all administrative actions necessary to implement the attached listing of effective District fees.

Section 4. This resolution shall be effective upon adoption.

CERTIFICATION

The foregoing Resolution No. 2018- 6 was adopted at a regular meeting on Oct. 16 2018, by the following vote:

AYES:

5

NOES:

0

ABSTENTIONS:

0

ABSENCES:

0

Felipe Cruz
Secretary of the Board of Directors

**Calwa Recreation and Park District
Facilities Fees**

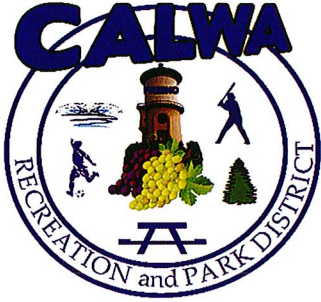
Administrative Fee	TBD
Key Deposit (Refundable)	\$50.00
Liability Insurance (required/unless furnished)	TBD
Security Guards (required with over 100 participants or if alcohol use)	TBD
Portable Restrooms	TBD
Waste Bin/Roll off	TBD
CALWA COMMUNITY HALL	
Cleaning Deposit (Refundable if no extra cleaning required by Calwa)	\$250.00
All Day Rental Fee w/Kitchen-includes tables & chairs	
Residents	400-600
Non-Residents	400-600
Rental Fee w/Kitchen-includes table & chairs	
Residents (Minimum 2-hour fee) / Each hour after 2 hr. requirement	100-200/75-150
Non-Residents (Minimum 2-hour fee) / Each hour after 2 hr. requirement	100-200/75-150
Resident Funeral Event	100-150
Non-Resident Funeral Event	100-150

EXCLUSIVE PARKS USE (Entire Park)	
Cleaning Deposit (Refundable if the park is left clean)	\$500.00
All Day Rental Fee (Non-Profit) Per Day	1000-2000
All Day Rental Fee Regular Organization	1500-2500
Art Wall	15-20 section
PARTIAL PARK RENTAL 1/4	
Cleaning Deposit (Refundable)	\$150.00
All Day Rental Fee (Non-Profit) Per Day	250-500
All Day Rental Fee Regular Organization	350-600
Will Need Contract Agreement	TBD

EXHIBIT A

PARK RENTAL: PICNIC AREA	
Rental Shelters (Areas)	35-50
Electricity (Additional Fee)	15-20
Bounce House Fee	15-30
SOFTBALL FIELDS	
Rental Softball Fields Per Game	25-50
Light Rental Use Per Hour	\$30.00
SOCCER FIELDS	
Adult Per Game / Lights Per Hour	\$50.00/\$30.00
Adult Non-Profit Per Game / Lights Per Hour	\$40.00/\$24.00
Youth Per Game/ Lights Per Hour	\$35.00/\$25.00
Youth Non-Profit Per Game / Lights Per Hour	\$30.00/\$20.00

**Calwa Recreation and Park District
Agenda Item Transmittal**



Meeting Date: October 15, 2019

Agenda Item Number: H-3

Wording for Agenda: Discuss Soccer Fields and Soccer Practices

Submitting: District Administrator

Contact Name and Phone Number: Felix Ortiz
559-264-6867

Department Recommendation: No recommendation

Summary/Background:

Attached is the Soccer Practice Schedule which will be discussed at this meeting.

Prior Board Actions: None

Attachments: Soccer Practice Schedule and Field Map

Recommended motion to be made by Board: None. Information only.

For action by:

District Board

Regular Session:

Consent Calendar

Regular Item

Public Hearing

Review:

**District Administrator
(Initials Required)**



Calwa Recreation and Park District

OFFICE OF DISTRICT ADMINISTRATOR
PHONE (559) 264-6867 CELL (559) 476-9309

4545 E. CHURCH AVENUE
FRESNO, CALIFORNIA 93725

CALWA RECREATION AND PARK POLICY ON PRACTICE AREAS AND FIELDS

For Coaches and Parents

Staff at Calwa Recreation and Park District have actively pursued ideas to find ways that we can better structure soccer practice to produce less wear and tear on the fields. As parents, coaches, and volunteers we must remember that all the fields are maintained by Calwa Recreation and Park District employees. We must help keep these fields in good shape, so the kids can continue to play on them. Therefore, Calwa Park has changed practice schedules.

The underlying principle is as follows:

The practice field will be used for two hours per team twice a week. Our focus is to get the coaches and the players to concentrate on fundamental development and having enough time to do so.

Having specific fields should eliminate any disagreement on who is practicing on what section of the field each day and time. We all want to have quality fields to practice on.

We require everyone's help in this matter. Calwa Recreation will put a schedule together. This schedule will be kept at the Calwa Park Office. Calwa Park will know what team should be on the field. Teams can no longer go and play on any field. Calwa staff will be walking the fields and making sure each coach has a card provided to you by the District Office. If the Calwa representative sees a coach/team practicing on the wrong field, they will receive one written warning. If they are uncooperative again their team will be dropped from the schedule.

If you would like to play a game or scrimmage game, you must go by the office and reserve a field at a cost of \$30.00 a game. Coaches practicing on that day on game field will be notified to cancel practice.

Remember we are doing this in the best interest of the kids to produce more practice areas for soccer teams to enjoy.

As District Administrator, I believe it is important that players continue to develop.

In summary offers:

- Practice specific areas
- A designated area for all teams to practice

It is required that:

- Coaches follow the Calwa Park District practice schedule
- Coaches educate parents and let them know why this is necessary

We hope to accomplish the following:

- Have practice areas where teams can train

SOCCER PRACTICE SCHEDULE					
MONDAY			WEDNESDAY		
	FIELD #1	NAME/PHONE #		FIELD #1	NAME/PHONE #
A	6:00-8:00 PM	JOSE MANUEL AREIGA 559-385-3197	A	6:00-8:00 PM	JOSE MANUEL AREIGA 559-385-3197
B	6:00-8:00 PM		B	6:00-8:00 PM	
C	5:00-8:00 PM	MARY ROSALES 559-978-4052	C	5:00-8:00 PM	MARY ROSALES 559-978-4052
D	5:00-8:00 PM	MARY ROSALES 559-978-4052	D	5:00-8:00 PM	MARY ROSALES 559-978-4052
	FIELD #2			FIELD #2	
A	6:00-8:00 PM	VICENTE FIGUEROA	A	6:00-8:00 PM	VICENTE FIGUEROA
B	6:00-8:00 PM	GUADALUPE HERNANDEZ	B	6:00-8:00 PM	GUADALUPE HERNANDEZ
C	6:00-8:00 PM	CARLOS VELASCO	C	6:00-8:00 PM	CARLOS VELASCO
D	6:00-8:00 PM	ANGEL BELTRAN	D	6:00-8:00 PM	ANGEL BELTRAN
	FIELD #3			FIELD #3	
A	6:00-8:00 PM	RICHARDO MEDINA 559-704-0892	A	6:00-8:00 PM	RICHARDO MEDINA 559-704-0892
B	6:00-8:00 PM	BRENDA JACINTO	B	6:00-8:00 PM	BRENDA JACINTO
C	6:00-8:00 PM	FRED SALAS	C	6:00-8:00 PM	FRED SALAS
D	6:00-8:00 PM	JULIE QUINTERO	D	6:00-8:00 PM	JULIE QUINTERO
TUESDAY			THURSDAY		
	FIELD #1	NAME/PHONE #		FIELD #1	NAME/PHONE #
A	6:00-8:00 PM	PEDRO LEMUS 559-385-4284	A	6:00-8:00 PM	PEDRO LEMUS 559-385-4284
B	6:00-8:00 PM	MARTIN RAMOS 559-930-4198	B	6:00-8:00 PM	MARTIN RAMOS 559-930-4198
C	6:00-8:00 PM		C	6:00-8:00 PM	
D	6:00-8:00 PM	LISA CASTILLO 559-776-7112	D	6:00-8:00 PM	LISA CASTILLO 559-776-7112
	FIELD #2			FIELD #2	
A	6:00-8:00 PM	VINCENT	A	6:00-8:00 PM	VINCENT
B	6:00-8:00 PM	MIGUEL HERNANDEZ 559-374-7154	B	6:00-8:00 PM	MIGUEL HERNANDEZ 559-374-7154
C	6:00-8:00 PM	JULIAN ENRIQUE 559-375-5776	C	6:00-8:00 PM	JULIAN ENRIQUE 559-375-5776
D	6:00-8:00 PM	JORJE DIAS 559-708-6417	D	6:00-8:00 PM	JORJE DIAS 559-708-6417
	FIELD #3			FIELD #3	
A	6:00-8:00 PM	MIGUEL MARTINEZ 559-473-5326	A	6:00-8:00 PM	MIGUEL MARTINEZ 559-473-5326
B	6:00-8:00 PM	ANGELICA RUIZ 559-374-4313	B	6:00-8:00 PM	ANGELICA RUIZ 559-374-4313
C	6:00-8:00 PM	VIVIAN MENDEZ 559-274-5320	C	6:00-8:00 PM	VIVIAN MENDEZ 559-274-5320
D	6:00-8:00 PM	JULIE QUINTERO	D	6:00-8:00 PM	JULIE QUINTERO
EVERY THREE MONTHS, COACHES MUST CONTACT THE CALWA RECREATION AND PARK DISTRICT TO KEEP THE SAME SPOT. IF NOT CONTACTED, TEAM MAY BE REPLACED.					

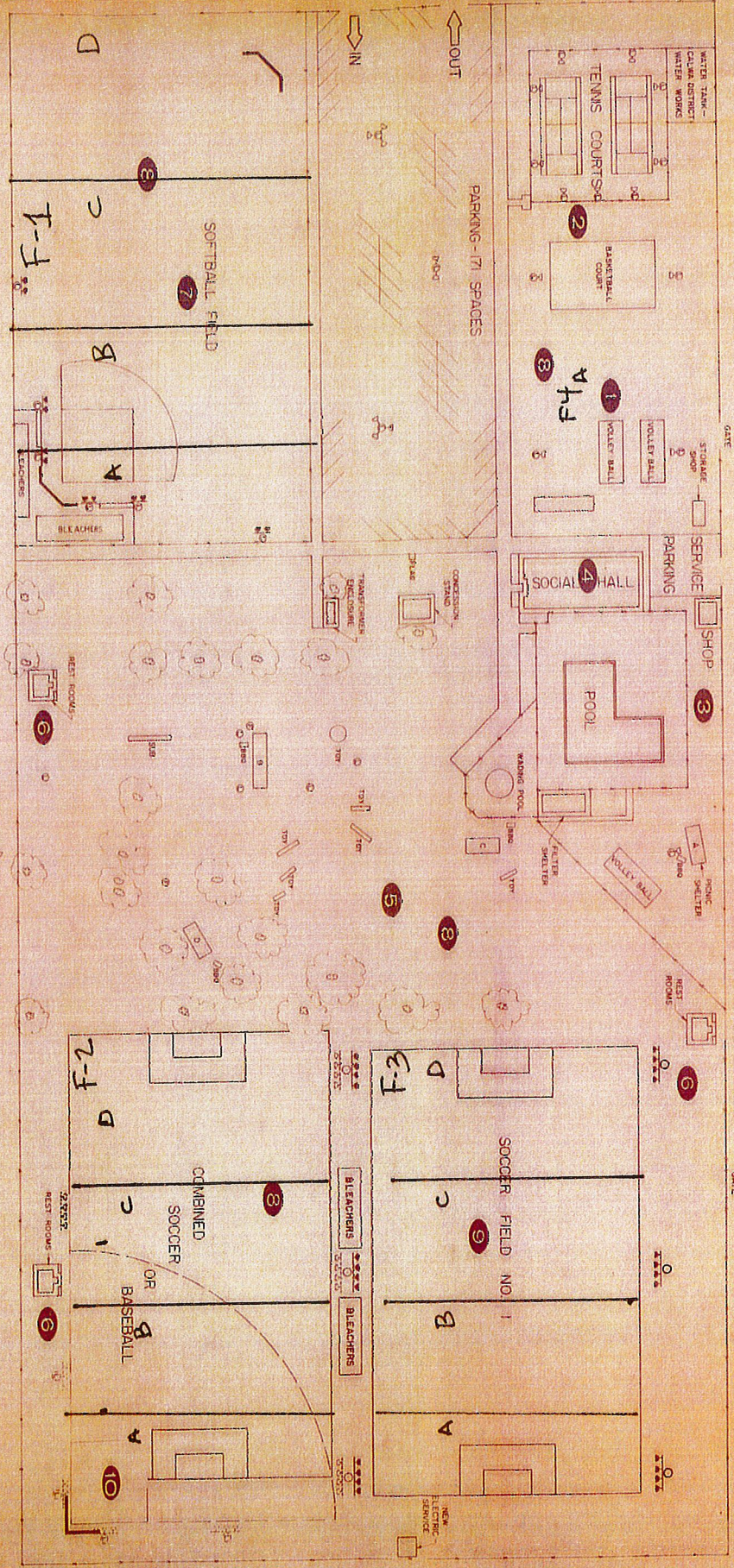
Copy to Mr. [unclear]

- 1 AREA OF FUTURE GYMNASIUM
- 2 AREA OF IMPROVED LIGHTING
- 3 EXPANSION OF SHOP FACILITIES
- 4 UPDATING & GENERAL BUILDING MODIFICATIONS
- 5 AREA OF IMPROVED PARK & PICNIC FACILITIES w/ LIGHTING
- 6 APPROXIMATE LOCATION OF FUTURE REST ROOMS
- 7 AREA OF IMPROVED LIGHTING & ADDED BASEBALL FACILITIES
- 8 AREAS OF NEW AND IMPROVED IRRIGATION
- 9 AREA OF NEW SOCCER w/ SPECTATOR ITEMS, LIGHTING
- 10 AREA OF IMPROVED DOUBLE-USE FIELD w/ NEW LIGHTING, SPECTATOR ITEMS, & IMPROVED FACILITIES

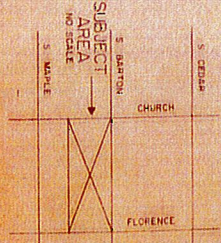
MASTER SITE PLAN

SCALE 1" = 40'-0"

NORTH



LOT 43 SHD LOT 1115 OF
 SHOW AND TRACT BEHND
 THE N 1/2 OF SEC 13 T 4 S.
 R 10 E M 0 6 9 S 0 3 4
 OF PLATS, PAGE 28.



M P SHEET

date	12-1-76
job	146
eng	G.R.O.
inp	M.N.V.

E. P. S. inc.

ELECTRICAL POWER SYSTEMS, inc.

2016 MERCED STREET
 FRESNO, CALIFORNIA
 PH (209) 486-7230

MASTER PLAN

CALWA PARKS & RECREATION DISTRICT
 CALWA, CALIFORNIA