

| |
—
—

CALWA RECREATION & PARK DISTRICT MEETING AGENDA

www.calwarecreation.org

BOARD MEETING MINUTES October 15, 2019

Regular Session 6:30 P.M.

CALWA PARK HALL- 4545 E. CHURCH AVE., FRESNO, CALIFORNIA

BOARD CHAIRPERSON

Raul Guerra, Chair

DISTRICT ADMINISTRATOR

Felix Ortiz

BOARD VICE CHAIR

Mary L. Rosales Vice Chair

DISTRICT COUNSEL

Hilda Cant6 Montoy

BOARD MEMBERS

Jose Luis Sanchez, Board Member

Gabriela Mares, Board Member

Esmeralda Zamora, Board Member

The Calwa Recreation and Park District Board of Directors welcomes you to its meetings and encourages you to participate. This agenda contains a brief general description of each item that will be considered by the Board. All attendees are advised that pagers, cell phones, and any other communication devices should be powered off upon entering the Board meeting.

The Board may consider and act on an agenda item in any order it deems appropriate. Actual timed items may be heard later but not before the time set on agenda. Persons interested in an item listed on the agenda are advised to be present throughout the meeting to ensure their presence when the item is called.

A. Call to Order and Roll Call

Meeting was called to order at 6:28 p.m. Board Chairperson Raul Guerra was present; Board Vice Chair Mary L. Rosales was present; Board Member Jose Luis Sanchez was present; Board Member Gabriela Mares was present; Board Member Esmeralda Zamora was present.

B. Invocation and Flag Salute

Invocation and Flag Salute were led by Board Vice Chair Mary L. Rosales.

C. Approval of Agenda

Agenda was approved, Motion was made by Board Member Jose Luis Sanchez, Seconded by Board Member Gabriela Mares. 5-0 approved and 0-opposed.

D. Ceremonial Matters and Presentations

Each presentation is limited to five (5) minutes.

Gunner Santos who is Calwa Recreation and Park District Recreational and Programs

Director came to speak about the Afterschool tutoring that he is operating free of charge to the community Monday-Friday from 2:00 p.m. to 6:00p.m. how is has six kids attending to receive help with homework.

How he is planning the Spooky Celebration for Halloween here at Calwa on October 31, 2019 from 5:00 p.m. to 7:00 p.m. there will be bounce houses, games, pumpkin painting and trunk or treating.

As well as planning to hold a soccer conditioning six-week program to start November 2, 2019 here at Calwa for the kids for only \$20 that included a t-shirt and a water bottle. The program will be led by a recent Fresno State graduate with a degree of physical science.

E. PUBLIC COMMENT

None

Members of the public wishing to address the District on an item that is not on the agenda may do so now. No action will be taken by the Board this evening. But items presented may be referred to the Administrator for follow up and a report. In order to allow time for all comments, each individual is limited to three minutes,

2. Consider Potential Facilities Fees Increase and Provide Direction to Staff on Potential New Resolution to increase Calwa Recreation and Park District Facilities Fees. **(A) — District Administrator**

Direction to Staff: Table item on next board meeting on November 19, 2019 with pricing comparisons from Mosqueda Recreation Center and Malaga Recreation Center. Motion was made by Jose Luis Sanchez and Seconded by Esmeralda Zamora. 5-0 approved and 0-opposed

3. Discuss Soccer Fields and Soccer Practices — **District Administrator**

Went over the Calwa Recreation and Park Policy on Practice Areas and Fields Sheet. Board Members asked about the soccer net barrier being put up, District Administrator explained that we needed the cherry picker. Basketball nets needing to be replaced.

I. CLOSED SESSION

None

1. REPORT OF FINAL ACTIONS TAKEN IN CLOSED SESSION, IF ANY

J. ADJOURNMENT

Meeting was adjourned at 7:20 p.m.

Agenda packets and other public documents are available for inspection by the public at the District Office located at 4545 E. Church Avenue, Fresno, CA. To receive meeting agendas by email, you can ask to be added to the mailing list by calling (559) 264-6867 or send your request by email to info@calwarecreation.org.

Any writings or documents provided to a majority of the Board Members less than 72 hours before a regular meeting regarding any item on this agenda will be made available for public inspection during normal business hours, at District Office and posted on the District wall. The documents will also be made available on the District's website at www.calwarecreation.org.

NEXT MEETING:

November 19, 2019

with a fifteen (15) minute maximum per group, per item, per meeting. When addressing the Board, you are requested to come forward to the speaker's microphone, state your name and address, and then proceed with your comments. All speakers are requested to wait until recognized by the Board Chair.

F. CONSENT CALENDAR (all items listed under the Consent Calendar are considered to be routine and will be enacted by one motion. For any discussion of an item on the Consent Calendar, it will be enacted at the request of any member of the Board and made a part of the regular agenda.

1. Minutes, August 20, 2019
2. Financials, August 31, 2019
3. Financials, September 30, 2019

A summary of Calwa Recreation and Park District bank accounts were given by District Administrator.

Board Chairperson Raul Guerra asked that in the budget "actuals" be included. Office Supply line was questioned on budget of \$924.26. The Board Members would like the separation between Office supplies and Recreation and Program supplies.

Consent Calendar was approved, Motion was made by Board Vice Chair Mary L. Rosales, Seconded by Board Member Esmeralda Zamora. 5-0 approved and 0-opposed.

G. OLD BUSINESS

1. Update on the Swimming Pool Construction — **District Administrator**

Swimming pool measurements were taken today for bathrooms. Groundbreaking is tentatively set to begin on the week of October 21, 2019, we will be notified 1-2 days in advanced.

H. NEW BUSINESS

1. Review Possibility of LED Retrofit for all Soccer Field Lights — **District Administrator**

The Board Members asked that they be presented with more information of what the spending costs and the savings would be for this specific LED Retrofit and at the cost of just replacing/repairing all the light fixtures. Look into buying better bulbs such as LED bulbs.

Direction to Staff: Table item on next board meeting on November 19, 2019. and to bring back presentations on costs and savings on both lighting options.

Certification of Posting

State of California

County of Fresno

Calwa Recreation and Park District

I declare under penalty of perjury that I am employed by the Calwa Recreation and Park District and that I posted this Agenda on the bulletin board in the Calwa Recreation District Office and the front door window of the District Office on October __, 2019.

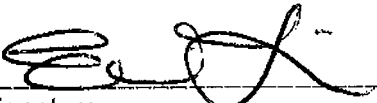
Signature

	Jul-19	Aug-19	Sep-19	Oct-19	Nov-19	Dec-19	Jan-20	Feb-20	Mar-20	Apr-20	May-20	Jun-20	YTD TOTAL	Total	Dollar	Percentage Left
Employee Cost																
Employee Salary	\$ 17,647.00	\$ 15,547.00	\$ 16,547.00	\$ 22,878.00	\$ 15,547.00	\$ 15,547.00	\$ 15,547.00	\$ 15,547.00	\$ 15,547.00	\$ 22,879.00	\$ 16,547.00	\$ 19,102.00	\$ 65,281.69	\$ 208,882.00	\$ 143,600.31	68.75%
Overtime	\$ 75.00	\$ 75.00	\$ 75.00	\$ 75.00	\$ 75.00	\$ 75.00	\$ 75.00	\$ 200.00	\$ 200.00	\$ 200.00	\$ 200.00	\$ 200.00	\$ 1,525.00	\$ 1,525.00		
Payroll Taxes	\$ 1,392.00	\$ 1,392.00	\$ 1,392.00	\$ 2,169.00	\$ 1,392.00	\$ 1,392.00	\$ 1,392.00	\$ 1,392.00	\$ 1,392.00	\$ 2,169.00	\$ 1,392.00	\$ 1,392.00	\$ 5,560.97	\$ 18,258.00	\$ 12,697.03	69.54%
Payroll Fees	\$ 208.00	\$ 208.00	\$ 208.00	\$ 208.00	\$ 208.00	\$ 208.00	\$ 208.00	\$ 208.00	\$ 208.00	\$ 208.00	\$ 208.00	\$ 208.00	\$ 666.66	\$ 2,496.00	\$ 1,829.34	73.29%
Director Stipend	\$ 1,000.00	\$ 1,000.00	\$ 500.00	\$ 500.00	\$ 500.00	\$ 500.00	\$ 500.00	\$ 500.00	\$ 500.00	\$ 500.00	\$ 500.00	\$ 1,000.00	\$ 2,200.00	\$ 7,500.00	\$ 5,300.00	70.67%
Workers Comp	\$ 8,000.00	\$ -	\$ -	\$ -	\$ -	\$ -	\$ -	\$ -	\$ -	\$ -	\$ -	\$ -	\$ 179.46	\$ 8,000.00	\$ 7,820.54	97.76%
HR miscellaneous	\$ 144.00	\$ 144.00	\$ 144.00	\$ 144.00	\$ 144.00	\$ 144.00	\$ 144.00	\$ 144.00	\$ 144.00	\$ 144.00	\$ 144.00	\$ 144.00	\$ 679.09	\$ 1,728.00	\$ 1,048.91	60.70%
Total	\$ 28,466.00	\$ 18,366.00	\$ 18,866.00	\$ 25,974.00	\$ 17,866.00	\$ 17,866.00	\$ 17,866.00	\$ 17,991.00	\$ 17,991.00	\$ 26,100.00	\$ 18,991.00	\$ 22,046.00	\$ 74,567.87	\$ 248,389.00	\$ 173,821.13	69.98%

Expenses	Jul-18	Aug-18	Sep-18	Oct-18	Nov-18	Dec-18	Jan-19	Feb-19	Mar-19	Apr-19	May-19	Jun-19	Total		
Audit	\$ -	\$ -	\$ -	\$ -	\$ -	\$ -	\$ 8,000.00	\$ -	\$ -	\$ -	\$ -	\$ -	\$ 8,000.00	\$ 8,000.00	100.00%
Bank Fees	\$ 22.00	\$ 22.00	\$ 22.00	\$ 22.00	\$ 22.00	\$ 22.00	\$ 22.00	\$ 22.00	\$ 22.00	\$ 22.00	\$ 22.00	\$ 22.00	\$ 264.00	\$ 264.00	99.81%
Cleaning Supplies	\$ 1,200.00	\$ 500.00	\$ 500.00	\$ 400.00	\$ 500.00	\$ 300.00	\$ 350.00	\$ 500.00	\$ 800.00	\$ 350.00	\$ 500.00	\$ 500.00	\$ 6,400.00	\$ 4,589.90	71.72%
District Counsel	\$ 1,000.00	\$ 1,000.00	\$ 1,000.00	\$ 1,000.00	\$ 1,000.00	\$ 1,000.00	\$ 1,000.00	\$ 1,000.00	\$ 1,000.00	\$ 1,000.00	\$ 1,000.00	\$ 1,000.00	\$ 12,000.00	\$ 10,395.00	86.63%
District Board Elections	\$ 150.00	\$ 780.00	\$ 675.00	\$ -	\$ -	\$ -	\$ -	\$ -	\$ -	\$ -	\$ -	\$ -	\$ 1,605.00	\$ 3,000.00	100.00%
Electricity	\$ 3,050.00	\$ 2,650.00	\$ 3,750.00	\$ 2,750.00	\$ 2,610.00	\$ 3,050.00	\$ 2,750.00	\$ 3,150.00	\$ 2,800.00	\$ 3,650.00	\$ 3,150.00	\$ 2,838.00	\$ 36,198.00	\$ 23,159.07	63.98%
Equipment Fuel	\$ 2,971.97	\$ 3,357.46	\$ 3,656.96	\$ 3,072.54	\$ 125.00	\$ 65.00	\$ 180.00	\$ 150.00	\$ 130.00	\$ 118.00	\$ 97.00	\$ 118.00	\$ 13,038.93	\$ 1,505.00	63.98%
Event Costs	\$ 114.00	\$ 150.00	\$ 140.00	\$ 118.00	\$ 125.00	\$ 225.00	\$ 225.00	\$ 225.00	\$ 225.00	\$ 225.00	\$ 225.00	\$ 225.00	\$ 549.43	\$ 2,700.00	63.49%
Fresno Co Service Fees	\$ 225.00	\$ 225.00	\$ 225.00	\$ 225.00	\$ 225.00	\$ 225.00	\$ 225.00	\$ 225.00	\$ 225.00	\$ 225.00	\$ 225.00	\$ 225.00	\$ 2,700.00	\$ 2,700.00	100.00%
Liability Insurance	\$ -	\$ -	\$ -	\$ -	\$ -	\$ -	\$ -	\$ -	\$ -	\$ -	\$ -	\$ -	\$ -	\$ 750.00	100.00%
Internet	\$ 5,000.00	\$ -	\$ -	\$ 47.50	\$ -	\$ -	\$ 5,000.00	\$ -	\$ -	\$ -	\$ -	\$ -	\$ 47.50	\$ 10,000.00	100.00%
Landline Phone	\$ 180.00	\$ 170.00	\$ 210.00	\$ 166.00	\$ 210.00	\$ 210.00	\$ 200.00	\$ 166.00	\$ 210.00	\$ 210.00	\$ 170.00	\$ 201.00	\$ 2,303.00	\$ 9,952.50	99.53%
Mobile Phone	\$ 319.98	\$ 159.99	\$ 159.99	\$ 139.00	\$ 160.00	\$ 160.00	\$ 130.00	\$ 120.00	\$ 160.00	\$ 250.00	\$ 160.00	\$ 210.00	\$ 639.96	\$ 1,663.04	72.21%
Memberships	\$ 120.00	\$ 159.33	\$ 317.70	\$ 21.18	\$ 120.00	\$ 120.00	\$ 120.00	\$ 120.00	\$ 120.00	\$ 120.00	\$ 120.00	\$ 120.00	\$ 655.93	\$ 1,870.00	64.92%
Mileage	\$ 93.01	\$ 98.43	\$ 94.61	\$ 94.61	\$ -	\$ 1,300.00	\$ -	\$ -	\$ -	\$ -	\$ -	\$ -	\$ 380.66	\$ 1,440.00	73.57%
Office Equipment	\$ 100.00	\$ -	\$ -	\$ 1,421.00	\$ -	\$ -	\$ -	\$ -	\$ -	\$ -	\$ -	\$ -	\$ 1,421.00	\$ 1,920.00	25.99%
Office Supplies	\$ 210.00	\$ 170.00	\$ 170.00	\$ 100.00	\$ 180.00	\$ 175.00	\$ 170.00	\$ 200.00	\$ 275.00	\$ 150.00	\$ 150.00	\$ 150.00	\$ 2,100.00	\$ 100.00	100.00%
Professional Development	\$ 266.01	\$ -	\$ 161.37	\$ 139.00	\$ -	\$ 296.00	\$ 70.00	\$ 50.00	\$ 270.00	\$ 131.00	\$ 85.00	\$ 85.00	\$ 566.38	\$ 1,572.00	73.03%
Recreation Programs	\$ 85.00	\$ 100.00	\$ 50.00	\$ 170.00	\$ 180.00	\$ 296.00	\$ 70.00	\$ 50.00	\$ 270.00	\$ 131.00	\$ 85.00	\$ 85.00	\$ 1,572.00	\$ 1,572.00	7.15%
Repairs and Maintenance	\$ 227.90	\$ 924.26	\$ 274.50	\$ 33.00	\$ -	\$ -	\$ -	\$ -	\$ -	\$ -	\$ -	\$ -	\$ 1,459.66	\$ 1,000.00	100.00%
Security	\$ 600.00	\$ 500.00	\$ 400.00	\$ 400.00	\$ 400.00	\$ 300.00	\$ 300.00	\$ 300.00	\$ 308.00	\$ 450.00	\$ 450.00	\$ 450.00	\$ 4,858.00	\$ 4,858.00	100.00%
Security Monitoring System	\$ 408.56	\$ (192.09)	\$ (170.00)	\$ 326.38	\$ -	\$ -	\$ -	\$ -	\$ -	\$ -	\$ -	\$ -	\$ 372.85	\$ 52,300.00	92.33%
Technology Services	\$ 2,500.00	\$ 2,500.00	\$ 8,000.00	\$ 4,800.00	\$ 5,000.00	\$ 5,000.00	\$ 5,000.00	\$ 5,000.00	\$ 5,000.00	\$ 3,500.00	\$ 3,500.00	\$ 2,500.00	\$ 52,300.00	\$ 52,300.00	100.00%
Trash Disposal	\$ 9,006.51	\$ 3,354.68	\$ 2,513.11	\$ 1,989.43	\$ -	\$ -	\$ 500.00	\$ -	\$ 350.00	\$ 500.00	\$ -	\$ 500.00	\$ 2,350.00	\$ 1,864.00	79.32%
Vehicle leasing/Financing	\$ 486.00	\$ -	\$ 10.00	\$ 260.00	\$ 10.00	\$ 10.00	\$ 10.00	\$ 260.00	\$ 10.00	\$ 10.00	\$ 10.00	\$ 10.00	\$ 620.00	\$ 1,864.00	79.32%
Water	\$ 10.00	\$ 10.00	\$ 417.17	\$ 496.00	\$ 10.00	\$ 10.00	\$ 10.00	\$ 260.00	\$ 10.00	\$ 10.00	\$ 10.00	\$ 10.00	\$ 620.00	\$ 1,864.00	79.32%
swimming pool maintenance	\$ 90.00	\$ 90.00	\$ 75.00	\$ 90.00	\$ 120.00	\$ 120.00	\$ 100.00	\$ 90.00	\$ 100.00	\$ 90.00	\$ 100.00	\$ 90.00	\$ 1,170.00	\$ (313.17)	-50.51%
swimming pool construction	\$ 150.00	\$ 250.00	\$ 250.00	\$ 250.00	\$ 250.00	\$ 250.00	\$ 250.00	\$ 250.00	\$ 250.00	\$ 250.00	\$ 250.00	\$ 250.00	\$ 3,000.00	\$ 945.00	80.77%
Total	\$ 239.14	\$ 242.73	\$ 239.14	\$ 511.88	\$ 250.00	\$ 250.00	\$ 250.00	\$ 250.00	\$ 250.00	\$ 250.00	\$ 250.00	\$ 250.00	\$ 3,000.00	\$ 1,232.89	59%
	\$ 375.00	\$ 375.00	\$ 375.00	\$ 375.00	\$ 375.00	\$ 375.00	\$ 375.00	\$ 375.00	\$ 375.00	\$ 375.00	\$ 375.00	\$ 375.00	\$ 4,500.00	\$ (16,161.68)	459%
	\$ 296.80	\$ (17,052.08)	\$ 296.80	\$ 296.80	\$ 296.80	\$ 296.80	\$ 296.80	\$ 296.80	\$ 296.80	\$ 296.80	\$ 296.80	\$ 296.80	\$ 35,000.00	\$ 20,661.68	459%
	\$ 3,000.00	\$ 4,200.00	\$ 3,600.00	\$ 4,400.00	\$ 3,800.00	\$ 2,850.00	\$ 2,000.00	\$ 2,000.00	\$ 1,500.00	\$ 2,500.00	\$ 2,500.00	\$ 2,550.00	\$ 2,650.00	\$ 15,808.21	55%
	\$ 2,849.48	\$ 5,279.25	\$ 7,679.48	\$ 6,581.01	\$ 3,800.00	\$ 2,850.00	\$ 2,000.00	\$ 2,000.00	\$ 1,500.00	\$ 2,500.00	\$ 2,500.00	\$ 2,550.00	\$ 3,000.00	\$ 19,191.79	55%
	\$ -	\$ -	\$ -	\$ -	\$ -	\$ -	\$ -	\$ -	\$ -	\$ -	\$ -	\$ -	\$ -	\$ 3,000.00	100%
	\$ -	\$ -	\$ 80,000.00	\$ -	\$ -	\$ 50,000.00	\$ -	\$ -	\$ 50,000.00	\$ -	\$ -	\$ 70,000.00	\$ 250,000.00	\$ 250,000.00	100%
Grand Total	\$ 18,251.00	\$ 16,812.00	\$ 101,032.00	\$ 15,766.00	\$ 16,287.00	\$ 65,828.00	\$ 26,752.00	\$ 13,978.00	\$ 63,905.00	\$ 13,901.00	\$ 12,864.00	\$ 84,544.00	\$ 449,920.00	\$ 401,328.77	89%
	\$ 17,900.78	\$ (1,745.40)	\$ 16,914.62	\$ 15,521.23	\$ -	\$ 29,625.00	\$ -	\$ -	\$ 63,905.00	\$ -	\$ -	\$ 84,544.00	\$ 449,920.00	\$ 401,328.77	89%
	#REF!	#REF!	#REF!	#REF!	#REF!	#REF!	#REF!	#REF!	#REF!	#REF!	#REF!	#REF!	\$ 698,309.00	#REF!	#REF!

Profit & Loss Budget Overview

Accrual Basis

October 2019

	Oct 19	Budget
Ordinary Income/Expense		
Income		
Park Income (Income recieved from Park Rentals)		
Donation	0.00	0.00
Events	515.00	2,450.00
Field Rentals	0.00	150.00
Hall Rentals	555.00	100.00
Miscellaneous	0.00	1,450.00
Picnic Rental	35.00	100.00
Rent Payments	1,900.00	1,400.00
Zumba	600.00	600.00
Total Park Income (Income recieved from Park Rentals)	3,605.00	6,250.00
The County of Fresno		
2230-unassigned funds	0.00	0.00
3005-RDA ABX1 26 Property Tax	0.00	0.00
3006-Redev Tax Increm Reimb	0.00	0.00
3008-Suppl-Prior Secured	121.58	0.00
3009-suppl-Current Unsecured	0.00	0.00
3010-Property Taxes	0.00	0.00
3011-Suppl-Current Secured	538.02	0.00
3013-Supplemental Curr unsecure	35.62	0.00
3015-Property Taxes-current Uns	0.00	0.00
3017-Property Taxes-Curr Unsec	134.84	0.00
3025-Property Taxes-Prior Unsec	0.00	0.00
3030-Penalties & Costs	47.55	0.00
3380-Interest	89.43	0.00
3565-State-I/L Homeowners Prop	0.00	0.00
4369- Federal In lieu housing	0.00	0.00
5804-ABX126 Other Revenue	0.00	0.00
The County of Fresno - Other	0.00	28,025.00
Total The County of Fresno	967.04	28,025.00
Total Income	4,572.04	34,275.00
Gross Profit	4,572.04	34,275.00
Expense		
Aflac (Health Insurance)	-58.68	0.00
Audit	0.00	0.00
Bank Fees	0.00	22.00
Cleaning supplles	336.54	400.00
Director stipends	0.00	500.00
District counsel	0.00	1,000.00
District Payroll Taxes	1,899.86	2,169.00
Electricity	3,072.54	2,750.00
Employee Salaries	21,943.87	22,878.00
Equipment Fuel	79.36	118.00
Event Costs	0.00	225.00
Fresno co Service fee	0.00	0.00
HR miscellaneous	-2,545.46	144.00
Internet	0.00	166.00
Landline Phone	21.18	120.00
Liability insurance	47.50	0.00
Memberships	1,421.00	0.00
Mileage	0.00	0.00
Mobile Phone	94.61	120.00
Office Equipment	139.00	100.00
Office Supply	33.00	170.00
Payroll Fees	153.96	208.00
Professional Development	0.00	0.00
Recreation Programs	326.38	400.00
Repairs and Maintenance	1,989.43	4,800.00
Security	0.00	0.00
Security Monitoring System	496.00	10.00
Technology Service	75.00	90.00
Trash Disposal	511.88	250.00
Vehicle Leasing	296.80	375.00
Water	6,581.01	4,400.00
Workers Compensation	0.00	0.00
Total Expense	36,914.78	41,415.00
Net Ordinary Income	-32,342.74	-7,140.00
Other Income/Expense		
Other Expense		
Ask My Accountant (Transactions to be discussed with accountant, consultant, or tax preparer)	182.27	
Total Other Expense	182.27	
Net Other Income	-182.27	0.00
Net Income	-32,525.01	-7,140.00

Reconciliation Summary

Fresno County Account, Period Ending 10/31/2019

	Oct 31, 19
Beginning Balance	163,927.55
Cleared Transactions	
Checks and Payments - 16 items	-57,310.60
Deposits and Credits - 1 item	967.04
Total Cleared Transactions	-56,343.56
Cleared Balance	<u>107,583.99</u>
Uncleared Transactions	
Checks and Payments - 1 item	-20,000.00
Total Uncleared Transactions	-20,000.00
Register Balance as of 10/31/2019	<u>87,583.99</u>
New Transactions	
Checks and Payments - 2 items	-8,016.73
Total New Transactions	-8,016.73
Ending Balance	<u><u>79,567.26</u></u>

Reconciliation Detail

Fresno County Account, Period Ending 10/31/2019

Type	Date	Num	Name	Cir	Amount	Balance
Beginning Balance						163,927.55
Cleared Transactions						
Checks and Payments - 16 Items						
Check	10/04/2019	65-0284903	CALWA RECREATION AND PARK DI...	X	-20,000.00	-20,000.00
Check	10/04/2019	65-0284904	CALWA RECREATION AND PARK DI...	X	-10,379.67	-30,379.67
Check	10/04/2019	65-0284906	CALWA RECREATION AND PARK DI...	X	-7,899.83	-38,279.50
Check	10/04/2019	65-0284912	Central Sanitary Supply	X	-336.54	-38,616.04
Check	10/04/2019	65-0284907	Hilda Galaviz	X	-250.00	-38,866.04
Check	10/04/2019	65-0284905	KS StateBank	X	-162.53	-39,028.57
Check	10/04/2019	65-0284909	Laura Salvatierra	X	-10.00	-39,038.57
Check	10/04/2019	65-0284910	Blanca Parra	X	-10.00	-39,048.57
Check	10/04/2019	65-0284908	Brenda Malicder	X	-10.00	-39,058.57
Check	10/18/2019	65-0284916	CALWA RECREATION AND PARK DI...	X	-8,406.86	-47,465.43
Check	10/18/2019	65-0284919	CALWA RECREATION AND PARK DI...	X	-7,582.67	-55,048.10
Check	10/18/2019	65-0284920	California Special Districts Association	X	-1,421.00	-56,469.10
Check	10/18/2019	65-0284922	Jeff Pfeiffer	X	-550.00	-57,019.10
Check	10/18/2019	65-0284914	ROLANDO MADRIGAL	X	-140.00	-57,159.10
Check	10/18/2019	65-0284915	LIVE SCAN	X	-104.00	-57,263.10
Check	10/18/2019	65-0284921	SDRMA	X	-47.50	-57,310.60
Total Checks and Payments					-57,310.60	-57,310.60
Deposits and Credits - 1 Item						
Deposit	10/31/2019			X	967.04	967.04
Total Deposits and Credits					967.04	967.04
Total Cleared Transactions					-56,343.56	-56,343.56
Cleared Balance					-56,343.56	107,583.99
Uncleared Transactions						
Checks and Payments - 1 item						
Check	10/18/2019	65-0284917	CALWA RECREATION AND PARK DI...		-20,000.00	-20,000.00
Total Checks and Payments					-20,000.00	-20,000.00
Total Uncleared Transactions					-20,000.00	-20,000.00
Register Balance as of 10/31/2019					-76,343.56	87,583.99
New Transactions						
Checks and Payments - 2 Items						
Check	11/15/2019	65-0284923	CALWA RECREATION AND PARK DI...		-7,854.20	-7,854.20
Check	11/15/2019	65-0284925	KS StateBank		-162.53	-8,016.73
Total Checks and Payments					-8,016.73	-8,016.73
Total New Transactions					-8,016.73	-8,016.73
Ending Balance					-84,360.29	79,567.26

Journal Date	Jrnl Src	Jrnl ID	Header Description	Line Ref	Debit Amount	Credit Amount
Fund: 4660 Calwa Park And Recreation Dist SUBCLASS: 10000 ACCOUNT: 0110						
Sub class: 10000 General Subclass						
Account: 0110						
Cash In Treasury						
			Beginning Balance	163,927.55		39,058.57
10/03/2019	REC	0001886689	Op Fund Entry - Main			
10/04/2019	AUD	0001886768	20-PRIOR SECURED SUPPLEMEN PSS2 18-19		169.13	
10/04/2019	AUD	0001886775	20 - CURRENT SECURED SUPPL CSS2		304.00	
10/10/2019	AUD	0001887462	20 - CURRENT UNSECURED PRI CUP18-19		134.84	
10/10/2019	AUD	0001887465	20 - CURRENT UNSECURED PRI CUPS18-19		35.62	
10/17/2019	REC	0001888706	Op Fund Entry - Main			234.02
10/18/2019	AUD	0001888762	20 - CURRENT SECURED SUPPL CSS3		89.43	
10/18/2019	ALO	0001888916	1st QTR- 1st INT DISTB		967.04	
			Cash In Treasury			57,310.60
			Ending Balance	107,583.99		
Account: 2230						
Fund Balance - Unassigned						
			Beginning Balance	2,800,120.66		
10/03/2019	REC	0001886689	Op Fund Entry - Main			39,058.57
10/17/2019	REC	0001888706	Op Fund Entry - Main			18,252.03
			Fund Balance - Unassigned			57,310.60
			Ending Balance	2,857,431.26		0.00
Account: 3008						
Suppl-Prior Secured						
			Beginning Balance	0.00		
10/04/2019	AUD	0001886768	20-PRIOR SECURED SUPPLEMEN PSS2 18-19			121.58
			Suppl-Prior Secured		0.00	
			Ending Balance	-121.58		
Account: 3011						
Suppl-Current Secured						
			Beginning Balance	-2,872.68		
10/04/2019	AUD	0001886775	20 - CURRENT SECURED SUPPL CSS2			304.00
10/18/2019	AUD	0001888762	20 - CURRENT SECURED SUPPL CSS3			234.02
			Suppl-Current Secured		0.00	
			Ending Balance	-3,410.70		538.02
Account: 3013						
Supplemental-Curr Unsec Prior						
			Beginning Balance	0.00		
10/10/2019	AUD	0001887465	20 - CURRENT UNSECURED PRI CUPS18-19			35.62
			Supplemental-Curr Unsec Prior		0.00	
			Ending Balance	-35.62		35.62
Account: 3017						
Property Taxes-Curr Unsec Pr						
			Beginning Balance	0.00		
10/10/2019	AUD	0001887462	20 - CURRENT UNSECURED PRI CUP18-19			134.84
			Property Taxes-Curr Unsec Pr		0.00	
			Ending Balance	-134.84		134.84
Account: 3030						
Penalties & Costs-Delinq Taxes						
			Beginning Balance	0.00		
10/04/2019	AUD	0001886768	20-PRIOR SECURED SUPPLEMEN PSS2 18-19			47.55
			Penalties & Costs-Delinq Taxes		0.00	
			Ending Balance	-47.55		47.55
End of Report						

Fund: 4660 Calwa Park And Recreation Dist SUBCLASS: 10000 ACCOUNT: 3380

Journal Date	Jrnl Src	Jrnl ID	Header Description	Line Ref	Debit Amount	Credit Amount
			Beginning Balance		0.00	
			10/18/2019 ALO 0001888916 1st QTR- 1st INT DISTB			89.43
			Interest		0.00	89.43
			Ending Balance			
			Account Total			-89.43
			Subclass Total		58,277.64	58,277.64
			Fund Total		58,277.64	58,277.64

PeopleSoft
 MONTHLY GENERAL LEDGER TRIAL BALANCE

Fiscal Year 2020
 Through Period 4

Fund:	4660	Calwa Park And Recreation Dist	General Subclass	Beginning Balance	Year-to-Date	Transaction	Current Balances
Subclass:	10000			Debit Accts	Debits	Credits	Debits Accts
				Credit Accts			Credit Accts
0110	Cash In Treasury			279,610.17	0.00	172,026.18	107,583.99
0315	Interest Receivable			1,460.13	0.00	1,460.13	0.00
1435	Due To Other Governmental			0.00	0.00	0.00	0.00
1480	Fiduciary Closing			0.00	0.00	0.00	0.00
2230	Fund Balance - Unassigned			0.00	177,519.22	0.00	0.00
3008	Suppl-Prior Secured			0.00	0.00	121.58	0.00
3011	Suppl-Current Secured			0.00	0.00	3,410.70	0.00
3013	Supplemental-Curr Unsec Pr			0.00	0.00	35.62	0.00
3017	Property Taxes-Curr Unsec			0.00	0.00	134.84	0.00
3025	Property Taxes-Prior Unsec			0.00	0.00	193.19	0.00
3030	Penalties & Costs-Delinq T			0.00	0.00	47.55	0.00
3380	Interest			0.00	0.00	89.43	0.00
	SUB CLASS TOTAL			281,070.30	177,519.22	177,519.22	107,583.99

Report ID: GLSF9109
Program: GLSF9109

PeopleSoft
MONTHLY GENERAL LEDGER TRIAL BALANCE
Fiscal Year 2020
Through Period 4

Page No. 2
Run Date 11/04/2019
Run Time 09:05:40

Fund:	4660	Beginning Balance	Year-to-Date Transaction	Current Balances
Calwa Park And Recreation Dist		Debit Accts	Debits	Debits Accts
Subclass: 10000		Credit Accts	Credits	Credit Accts
General Subclass				
GRAND TOTALS		281,070.30	177,519.22	107,583.99
		281,070.30	177,519.22	107,583.99

End of Report

Reconciliation Summary

Bank of The West Revenue, Period Ending 10/31/2019

	Oct 31, 19
Beginning Balance	43,444.25
Cleared Transactions	
Checks and Payments - 20 items	-13,215.93
Deposits and Credits - 6 items	26,704.46
Total Cleared Transactions	13,488.53
Cleared Balance	<u>56,932.78</u>
Uncleared Transactions	
Deposits and Credits - 1 item	20,000.00
Total Uncleared Transactions	20,000.00
Register Balance as of 10/31/2019	<u>76,932.78</u>
New Transactions	
Checks and Payments - 2 Items	-600.00
Total New Transactions	-600.00
Ending Balance	<u>76,332.78</u>

Reconciliation Detail

Bank of The West Revenue, Period Ending 10/31/2019

Type	Date	Num	Name	Cir	Amount	Balance
Beginning Balance						43,444.25
Cleared Transactions						
Checks and Payments - 20 items						
Check	10/03/2019	DEBIT	PG and E	X	-3,072.54	-3,072.54
Check	10/04/2019	1112	Alberto Martinez	X	-200.00	-3,272.54
Check	10/04/2019	985020	Zoom Imaging Solutions INC	X	-56.03	-3,328.57
Check	10/09/2019	DEBIT	John Deere Financial	X	-134.27	-3,462.84
Check	10/09/2019	DEBIT	AT and T	X	-21.18	-3,484.02
Check	10/11/2019	DEBIT	Mid Valley Disposal	X	-511.88	-3,995.90
Check	10/11/2019	DEBIT	Sonitrol	X	-486.00	-4,481.90
Check	10/15/2019	985030	Home Depot Credit Card Serv...	X	-1,277.31	-5,759.21
Check	10/15/2019	DEBIT	Costco	X	-149.90	-5,909.11
Check	10/16/2019	985025	City of Fresno Utilities	X	-6,581.01	-12,490.12
Check	10/16/2019	DEBIT	Arco	X	-79.36	-12,569.48
Check	10/17/2019	DEBIT	Verizon Wireless	X	-94.61	-12,664.09
Check	10/18/2019	985029	De Lage Landon	X	-82.97	-12,747.06
Check	10/18/2019	DEBIT	Post Office	X	-33.00	-12,780.06
Check	10/21/2019	985022	Streamline	X	-75.00	-12,855.06
Check	10/21/2019	DEBIT	RING.COM	X	-10.00	-12,865.06
Check	10/23/2019	DEBIT	Jenson & Pilegard	X	-138.38	-13,003.44
Check	10/23/2019	DEBIT	Amazon.com	X	-23.74	-13,027.18
Check	10/28/2019	DEBIT	WayFair	X	-182.27	-13,209.45
Check	10/29/2019	DEBIT	Walmart	X	-6.48	-13,215.93
Total Checks and Payments					-13,215.93	-13,215.93
Deposits and Credits - 6 items						
Deposit	10/01/2019			X	1,324.73	1,324.73
Deposit	10/03/2019			X	2,255.00	3,579.73
Check	10/04/2019	65-0284903	CALWA RECREATION AND ...	X	20,000.00	23,579.73
Deposit	10/18/2019			X	865.00	24,444.73
Deposit	10/29/2019			X	935.00	25,379.73
Deposit	10/29/2019			X	1,324.73	26,704.46
Total Deposits and Credits					26,704.46	26,704.46
Total Cleared Transactions					13,488.53	13,488.53
Cleared Balance					13,488.53	56,932.78
Uncleared Transactions						
Deposits and Credits - 1 Item						
Check	10/18/2019	65-0284917	CALWA RECREATION AND ...		20,000.00	20,000.00
Total Deposits and Credits					20,000.00	20,000.00
Total Uncleared Transactions					20,000.00	20,000.00
Register Balance as of 10/31/2019					33,488.53	76,932.78
New Transactions						
Checks and Payments - 2 items						
Check	11/02/2019	1113	Daniel Moreno		-300.00	-300.00
Check	12/07/2019	1114	Daniel Moreno		-300.00	-600.00
Total Checks and Payments					-600.00	-600.00
Total New Transactions					-600.00	-600.00
Ending Balance					32,888.53	76,332.78



BANK OF THE WEST
BNP PARIBAS

P.O. Box 2830, Omaha, NE 68103-2830

Account Statement

October 1, 2019 - October 31, 2019

Page 1 of 4



>003947 3532361 0001 008230 10Z
 CALWA RECREATION & PARK DISTRICT
 4545 E CHURCH AVE
 FRESNO CA 93725-1537

At your service



bankofthewest.com



1-800-488-2265



1-800-659-5495 TTY

New online and mobile services!

Enjoy these new online card services: Online statements - Online and recurring payments - Dispute transactions - Travel notices - PIN change - Account alerts - Replacement cards - Card activation - Lock/unlock your card.

Simply log into your account at www.bankofthewest.com and go to the Services and Support page or on your mobile device on the More screen.

Remember to confirm your email during your next branch visit or call our Contact Center at 800-488-2265. Our emails keep you educated about our services, products and more.

CLASSIC BUSINESS CHECKING 036-438101

CALWA RECREATION & PARK DISTRICT

ACCOUNT SUMMARY

Beginning Balance	\$43,444.25
3 Credits	2,659.46
3 Deposits	24,055.00
15 Withdrawals	-4,953.61
6 Checks	-8,272.32
Ending Balance	\$56,932.78

EARNINGS SUMMARY

Interest this statement period	\$0.00
Interest credited year-to-date	\$0.00
Annual percentage yield earned	0.00%
Average monthly balance	\$48,229.20

For your protection:

Examine this statement promptly. Any discrepancy must be reported within 30 days. Consumer customers: A discrepancy regarding an electronic payment or line of credit must be reported within 60 days.

In South Dakota, Bank of the West operates under the name of Bank of the West California.



03947 3532361 007264 014527 0001/0002



CLASSIC BUSINESS CHECKING xxx-xx8101 (continued)

ACCOUNT DETAIL

Credits

<u>Date</u>	<u>Amount</u>	<u>Description</u>
10/01	\$10.00	SERVICE CHG REBATE VALUED CUSTOMER MONTHLY SERVICE CHARGE REBATE
10/01	1,324.73	ELECTRONIC DEP CALWA RECREATION DIRECT DEP 100119PPD
10/29	1,324.73	ELECTRONIC DEP CALWA RECREATION DIRECT DEP 102919PPD

3 credits for a total of \$2,659.46

Deposits

<u>Date</u>	<u>Amount</u>	<u>Date</u>	<u>Amount</u>	<u>Date</u>	<u>Amount</u>
10/03	\$2,255.00	10/18	\$20,865.00	10/29	\$935.00

3 deposits for a total of \$24,055.00

Withdrawals

<u>Date</u>	<u>Amount</u>	<u>Description</u>
10/01	\$10.00	MONTHLY SVC CHG PREVIOUS PERIOD ACTIVITY RESULTED IN MONTHLY SERVICE CHARGE
10/03	3,072.54	ELECTRONIC DBT PACIFIC GAS & EL ONLINE PMT 100319 CKF412279708POS CCD
10/09	21.18	ELECTRONIC DBT AT&T (PAC BELL) ONLINE PMT 100919 CKF412279708POS CCD
10/09	134.27	ELECTRONIC DBT JOHN DEERE CREDIT ONLINE PMT 100919 CKF412279708POS CCD
10/11	486.00	ELECTRONIC DBT SONITROL ONLINE PMT 101119 CKF412279708POS CCD
10/11	511.88	ELECTRONIC DBT MID VALLEY DISP ONLINE PMT 101119 CKF412279708POS CCD
10/15	149.90	POS PURCHASE 604911 COSTCO WHSE #13 CLOVIS CA ##9455
10/16	79.36	POS PURCHASE 044001 ARCO #42744 FRESNO CA ##9455
10/17	94.61	ELECTRONIC DBT VERIZON ONLINE PMT 101719 CKF412279708POS CCD
10/18	33.00	POS PURCHASE 002108 USPS PO 0 2382 S FRESNO CA ##9455
10/21	10.00	DEBIT CARD POS RING UNLIMITED MONTHLY 8006561918 CA ON 191021 #7602
10/23	138.38	DEBIT CARD POS JENSON & PILEGARD #2 FRESNO CA ON 191023 #9455
10/23	23.74	POS PURCHASE 000007 AMAZON.COM*QW0 SEATTLE WA ##9455
10/28	182.27	DEBIT CARD POS WAYFAIR*WAYFAIR WAYFAIR.COM MA ON 191027 #9455
10/29	6.48	POS PURCHASE 664126 Wal-Mart Super FRESNO CA ##9455

15 withdrawals for a total of \$4,953.61

Checks Paid

<u>Number</u>	<u>Date paid</u>	<u>Amount</u>	<u>Number</u>	<u>Date paid</u>	<u>Amount</u>	<u>Number</u>	<u>Date paid</u>	<u>Amount</u>
1112	10/08	200.00	985022*	10/21	75.00	985029*	10/18	82.97
985020*	10/04	56.03	985025*	10/16	6,581.01	985030	10/15	1,277.31

6 checks paid for a total of \$8,272.32

* Break in check number sequence.





IMPORTANT INFORMATION

IN CASE OF ERRORS OR QUESTIONS ABOUT YOUR ELECTRONIC TRANSFERS

(For accounts that are maintained primarily for personal, family or household purposes.)

Telephone us at (800) 488-2265, or write us at Bank of the West*, Branch Service Center, P.O. Box 2573, Omaha, NE 68103-2573 as soon as you can if you think your statement or receipt is wrong or if you need more information about a transfer listed on the statement or receipt. We must hear from you no later than 60 days after we sent you the FIRST statement on which the error or problem appeared. We will need to know the following:

1. Tell us your name and account number (if any).
2. Describe the error or the transfer you are unsure about, and explain as clearly as you can why you believe it is an error or why you need more information.
3. Tell us the dollar amount of the suspected error.

We will investigate your complaint and will correct any error promptly. If we take more than 10 business days (20 business days for transactions involving new accounts) to do this, we will credit your account for the amount you think is in error, so that you will have the use of the money during the time it takes us to complete our investigation.

03947 3532361 007265 014529 0002/0002

*In South Dakota, Bank of the West operates under the name of Bank of the West California.





BANK OF THE WEST
BNP PARIBAS

Account Statement

October 1, 2019 - October 31, 2019

Page 4 of 4

This space intentionally left blank.



bankofthewest.com



1-800-488-2265



1-800-659-5495 TTY

Reconciliation Summary

Bank of the West Payroll, Period Ending 10/31/2019

	Oct 31, 19
Beginning Balance	29,509.23
Cleared Transactions	
Checks and Payments - 12 items	-24,115.05
Deposits and Credits - 7 items	34,445.07
Total Cleared Transactions	<u>10,330.02</u>
Cleared Balance	<u><u>39,839.25</u></u>
Register Balance as of 10/31/2019	39,839.25
New Transactions	
Deposits and Credits - 1 item	7,854.20
Total New Transactions	<u>7,854.20</u>
Ending Balance	<u><u>47,693.45</u></u>

Reconciliation Detail

Bank of the West Payroll, Period Ending 10/31/2019

Type	Date	Num	Name	Clr	Amount	Balance
Beginning Balance						29,509.23
Cleared Transactions						
Checks and Payments - 12 items						
Check	10/01/2019	DEBIT	ADP	X	-5,736.30	-5,736.30
Check	10/01/2019	DEBIT	ADP	X	-1,898.56	-7,634.86
Check	10/01/2019	11026	Bobby D Otero	X	-772.00	-8,406.86
Check	10/02/2019	985020	Aflac Health	X	-117.36	-8,524.22
Check	10/11/2019	DEBIT	ADP	X	-76.98	-8,601.20
Check	10/16/2019	DEBIT	ADP	X	-5,247.42	-13,848.62
Check	10/16/2019	DEBIT	ADP	X	-1,707.16	-15,555.78
Check	10/17/2019	11027	Bobby D Otero	X	-628.09	-16,183.87
Check	10/25/2019	DEBIT	ADP	X	-76.98	-16,260.85
Check	10/29/2019	DEBIT	ADP	X	-5,406.95	-21,667.80
Check	10/29/2019	DEBIT	ADP	X	-1,747.26	-23,415.06
Check	10/30/2019	11028	Bobby D Otero	X	-699.99	-24,115.05
Total Checks and Payments					-24,115.05	-24,115.05
Deposits and Credits - 7 items						
Deposit	10/01/2019			X	58.68	58.68
Check	10/04/2019	65-0284906	CALWA RECREATI...	X	7,899.83	7,958.51
Check	10/04/2019	65-0284904	CALWA RECREATI...	X	10,379.67	18,338.18
Deposit	10/16/2019			X	58.68	18,396.86
Check	10/18/2019	65-0284919	CALWA RECREATI...	X	7,582.67	25,979.53
Check	10/18/2019	65-0284916	CALWA RECREATI...	X	8,406.86	34,386.39
Deposit	10/29/2019			X	58.68	34,445.07
Total Deposits and Credits					34,445.07	34,445.07
Total Cleared Transactions					10,330.02	10,330.02
Cleared Balance					10,330.02	39,839.25
Register Balance as of 10/31/2019					10,330.02	39,839.25
New Transactions						
Deposits and Credits - 1 item						
Check	11/15/2019	65-0284923	CALWA RECREATI...		7,854.20	7,854.20
Total Deposits and Credits					7,854.20	7,854.20
Total New Transactions					7,854.20	7,854.20
Ending Balance					18,184.22	47,693.45



BANK OF THE WEST
BNP PARIBAS

P.O. Box 2830, Omaha, NE 68103-2830

Account Statement

October 1, 2019 - October 31, 2019

Page 1 of 6

>001291 3535236 0001 008230 10Z
 CALWA RECREATION & PARK DISTRICT
 4545 E CHURCH AVE
 FRESNO CA 93725-1537



At your service



bankofthewest.com



1-800-488-2265



1-800-659-5495 TTY

New online and mobile services!

Enjoy these new online card services: Online statements - Online and recurring payments - Dispute transactions - Travel notices - PIN change - Account alerts - Replacement cards - Card activation - Lock/unlock your card.

Simply log into your account at www.bankofthewest.com and go to the Services and Support page or on your mobile device on the More screen.

Remember to confirm your email during your next branch visit or call our Contact Center at 800-488-2265. Our emails keep you educated about our services, products and more.

REGULAR BUSINESS CHECKING 097-005854

CALWA RECREATION & PARK DISTRICT

ACCOUNT SUMMARY

Beginning Balance	\$29,509.23
9 Credits	176.04
1 Deposits	34,269.03
8 Withdrawals	-21,897.61
4 Checks	-2,217.44
Ending Balance	\$39,839.25

EARNINGS SUMMARY

Interest this statement period	\$0.00
Interest credited year-to-date	\$0.00
Annual percentage yield earned	0.00%
Average monthly balance	\$31,884.27

For your protection:

Examine this statement promptly. Any discrepancy must be reported within 30 days. Consumer customers: A discrepancy regarding an electronic payment or line of credit must be reported within 60 days.

In South Dakota, Bank of the West operates under the name of Bank of the West California.



01291 3535236 003094 006187 0001/0003



REGULAR BUSINESS CHECKING xxx-xx5854 (continued)

ACCOUNT DETAIL

Credits

<i>Date</i>	<i>Amount</i>	<i>Description</i>
10/01	\$12.42	ELECTRONIC DEP CALWA RECREATION DIRECT DEP 100119PPD
10/01	16.32	ELECTRONIC DEP CALWA RECREATION DIRECT DEP 100119PPD
10/01	29.94	ELECTRONIC DEP CALWA RECREATION DIRECT DEP 100119PPD
10/16	12.42	ELECTRONIC DEP CALWA RECREATION DIRECT DEP 101619PPD
10/16	16.32	ELECTRONIC DEP CALWA RECREATION DIRECT DEP 101619PPD
10/16	29.94	ELECTRONIC DEP CALWA RECREATION DIRECT DEP 101619PPD
10/29	12.42	ELECTRONIC DEP CALWA RECREATION DIRECT DEP 102919PPD
10/29	16.32	ELECTRONIC DEP CALWA RECREATION DIRECT DEP 102919PPD
10/29	29.94	ELECTRONIC DEP CALWA RECREATION DIRECT DEP 102919PPD

9 credits for a total of \$176.04

Deposits

<i>Date</i>	<i>Amount</i>
10/18	\$34,269.03

1 deposit for a total of \$34,269.03

Withdrawals

<i>Date</i>	<i>Amount</i>	<i>Description</i>
10/01	\$1,898.56	ELECTRONIC DBT ADP Tax ADP Tax 100119 RRJIG 100120A01 CCD
10/01	5,736.30	ELECTRONIC DBT ADP WAGE PAY WAGE PAY 100119 797073768495JIG CCD
10/11	76.98	ELECTRONIC DBT ADP PAYROLL FEES ADP - FEES 101119 2RJIG 7915339 CCD
10/16	1,707.16	ELECTRONIC DBT ADP Tax ADP Tax 101619 RRJIG 101521A01 CCD
10/16	5,247.42	ELECTRONIC DBT ADP WAGE PAY WAGE PAY 101619 941011722084JIG CCD
10/25	76.98	ELECTRONIC DBT ADP PAYROLL FEES ADP - FEES 102519 2RJIG 9829516 CCD
10/29	1,747.26	ELECTRONIC DBT ADP Tax ADP Tax 102919 RRJIG 102922A01 CCD
10/29	5,406.95	ELECTRONIC DBT ADP WAGE PAY WAGE PAY 102919 942011898212JIG CCD

8 withdrawals for a total of \$21,897.61

Checks Paid

<i>Number</i>	<i>Date paid</i>	<i>Amount</i>	<i>Number</i>	<i>Date paid</i>	<i>Amount</i>
11026	10/02	772.00	11028	10/30	699.99
11027	10/17	628.09	985020*	10/02	117.36

4 checks paid for a total of \$2,217.44

* Break in check number sequence.





IMPORTANT INFORMATION

IN CASE OF ERRORS OR QUESTIONS ABOUT YOUR ELECTRONIC TRANSFERS (For accounts that are maintained primarily for personal, family or household purposes.)



Telephone us at (800) 488-2265, or write us at Bank of the West*, Branch Service Center, P.O. Box 2573, Omaha, NE 68103-2573 as soon as you can if you think your statement or receipt is wrong or if you need more information about a transfer listed on the statement or receipt. We must hear from you no later than 60 days after we sent you the FIRST statement on which the error or problem appeared. We will need to know the following:

1. Tell us your name and account number (if any).
2. Describe the error or the transfer you are unsure about, and explain as clearly as you can why you believe it is an error or why you need more information.
3. Tell us the dollar amount of the suspected error.

We will investigate your complaint and will correct any error promptly. If we take more than 10 business days (20 business days for transactions involving new accounts) to do this, we will credit your account for the amount you think is in error, so that you will have the use of the money during the time it takes us to complete our investigation.

01291 3535236 003095 006189 0002/0003

*In South Dakota, Bank of the West operates under the name of Bank of the West California.





BANK OF THE WEST
BNP PARIBAS

Account Statement

October 1, 2019 - October 31, 2019

Page 4 of 6

This space intentionally left blank.



bankofthewest.com



1-800-488-2265



1-800-659-5495 TTY



BANK OF THE WEST
BNP PARIBAS

Account Statement

October 1, 2019 - October 31, 2019

Page 6 of 6

This space intentionally left blank.



bankofthewest.com



1-800-488-2265



1-800-659-5495 TTY/TDD

**Calwa Recreation and Park District
Agenda Item Transmittal**

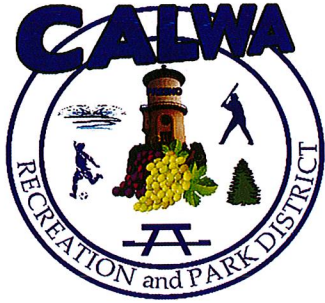

Meeting Date: November 19, 2019

Agenda Item Number: G-1

Wording for Agenda: Review and Possibility Approve moving forward to Retrofit all Soccer Field Lights.

Submitting: District Administrator

Contact Name and Phone Number: Felix Ortiz
559-264-6867

Department Recommendation: Approve moving forward to Retrofit all Soccer Field Lights.

Summary/Background:

Board ask me to locate Corncob bulbs to replace the light bulbs on the soccer Fields. I searched and couldn't find the Corncob style bulbs that would produces enough light. The Cob itself would block much of the light coming of the back side. If there is one big enough, it would produce so much heat it wouldn't last a year.

Included is an estimate for a different solution retrofitting the fixtures with a good quality retrofit (HiLumz Retrofit Kit) by using the same old fixtures with new electronics. In the end, this option will be approximately \$7,000.00 less expensive. The labor cost goes up as these require considerably more time to install than just swapping fixture to fixture. These fixtures produce the same number of lumens as the other fixtures (Linmore LED Site Lighter), they can lose approximately 20% of light output as they are recessed into the existing shoebox. Warranty 5 - years. Cost Approximately: \$118,000.00

Also included is the option to retrofit the entire fixture, which I presented at the last meeting). This include switching the entire fixtures and replace them with Linmore LED Site Lighter fixtures which includes a 10 - years warranty. Cost: \$124,000.000

By retrofitting the Calwa Recreation and Park District Soccer Lights, with either of these options, the District will reduce usage by approximately 75,160 kWh annually. This translates to approximately \$11,334 in annual savings. In addition to saving money, the fields will be brighter, safer, and more evenly illuminated.

Prior Board Actions: The Board asked District Administrator to bring back information on the cost of just replacing Corncob bulbs with LED bulbs.

For action by:

District Board

Regular Session:

Consent Calendar

Regular Item

Public Hearing

Review:

**District Administrator
(Initials Required)**

Attachments: Proposal for LED Retrofit and Proposal for Retrofit with Existing Boxes

Recommended motion to be made by Board: Move to approve moving forward to retrofit all Soccer Field Lights

LED Retrofit Proposal

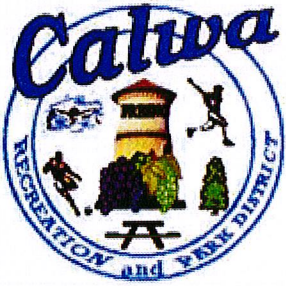

Calwa
Recreation and Park District

RETROFIT EXISTING SHOE BOXES

PROPOSAL BY:



TRUE NORTH LED

INSTALLATION BY:



Electrical Contractor, License #881252

TRUE NORTH LED | Tom Fernet | 661.205.2199
tom@truenorthled.com

Executive Summary

Calwa Recreation & Park District
October 17, 2019

Option 1, Primary Technology: LED, CA Based

Overall System Investment

Material Cost	Included
Labor Cost	Included
Recycling of Existing Fixtures in Accordance w/ CA Law	Included
Scissor and/or Boom Lift Rental	Included
System Design	Included
Project Management	Included
Rebate Administration and Acceptance as Payment*	Not Included
Surge Suppression	Not Included
Shipping	Included
Other Energy Conservations Measures (ECMs)	Not Included

Gross Investment	\$111,186
Less Rebate (Utility and/or Manufacturer)	\$0
Net Investment	\$111,186
Sales Tax (estimated)	\$6,737
Total	\$117,923

Profit from Upgrade

Annual Electrical Waste Reduction: Lighting & Controls	\$11,275
Annual Electrical Waste Reduction: HVAC, Source: R. Rundq	\$0
Annual Maintenance Savings	\$59
Rebate: Manufacturer/Instant (Expiration dates may apply, sub	\$0
Rebate: Utility Company (Subject to application and approval)	\$0

1st Year Profit from Upgrade **\$11,334**

Projected Annual Profit from Upgrade \$11,334
Average Monthly Profit from Upgrade \$944
Annual Kilowatt Hours Reduced 75,163
Demand Reduction, kW -

Financial Metrics

	10%	Important Dates
Return On Investment (ROI)	58.9	12/25/23
Breakeven Period in Months	117.7	11/25/28
Payback Period in Months		

10 Year Cash Flow

Year 1	(\$99,852)	Year 6	(\$43,184)
Year 2	(\$88,518)	Year 7	(\$31,851)
Year 3	(\$77,185)	Year 8	(\$20,517)
Year 4	(\$65,851)	Year 9	(\$9,183)
Year 5	(\$54,518)	Year 10	\$2,150

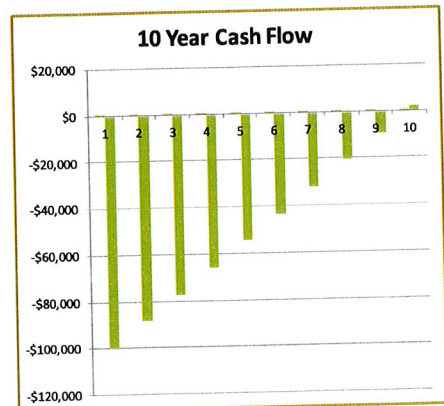
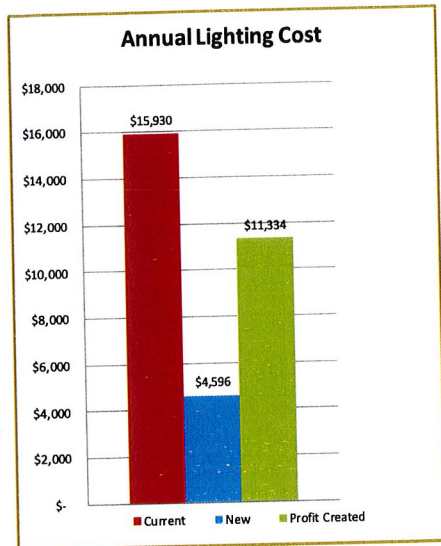

Lead Time: 4-5 Weeks or Less (Standard Products) Proposal Valid for 60 Days

OPTIONS (Check C)

I Would Like to use Purchase Order #: _____
 I Would Like to Pay by Credit Card (check here) _____
 I Would Like a Free Cash Flow Agreement (check here) _____

Terms: 50% On Order, Balance on Completion

Accepted By (print): _____ Date: _____

Signature: _____

TF

PLEASE EMAIL ACCEPTANCE TO tom@truenorthled.com

Project Data by Facility Area

Calwa Recreation & Park District
Falix Ortiz

Option 1

0.15 per kWh Rate Used
Date: October 17, 2019

True North Rep: TF
Utility Co: PG&E

#	Facility Area Description	Voltage	EXISTING				New Fixture or Retrofit	PROPOSED					ENERGY SAVINGS					ANNUAL SAVINGS		
			Qty	Fixture	Watts	Annual Hours		Fixture	Kelvin	Warr Years	Qty	Watts	Annual Hours	Existing Annual kWh	Lighting kWh Saved	Controls Savings	Controls kWh Saved		Total kWh Saved	kW (demand) Saved
1	S Field	480	20	1000w MH	1080	912	R	HLumz DM300 HIGH EFFICACY RETROFIT	5000	5	20	300	912	19,699	14,227	0	0	14,227	15.60	\$ 2,134
2	NW Field	480	33	1000w MH	1080	912	R	HLumz DM300 HIGH EFFICACY RETROFIT	5000	5	33	300	912	32,504	23,475	0	0	23,475	25.74	\$ 3,521
3	NE Field	480	47	1000w MH	1080	912	R	HLumz DM300 HIGH EFFICACY RETROFIT	5000	5	47	300	912	46,293	33,434	0	0	33,434	36.66	\$ 5,015
4	SW Field	480	6	1000w MH	1080	912	R	HLumz DM300 HIGH EFFICACY RETROFIT	5000	5	6	300	912	5,910	4,268	0	0	4,268	4.68	\$ 640
5	Basketball	480	12	100w MH	128	912	New	Linmore Site Lighter 150w HV + Surge Sup	5000	10	12	150	912	1,401	-241	0	0	-241	-0.26	\$ (36)
			118				Totals:					118	105,807	75,163	0	75,163	82.42	\$ 11,275		

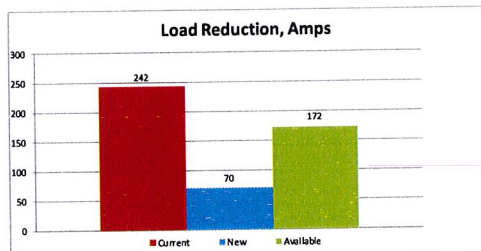

*Chart Data for Facility Areas on this Page Only

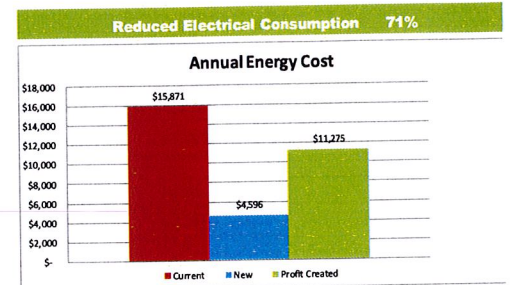

*Chart Data for Facility Areas on this Page Only

DM300 HIGH EFFICACY RETROFIT

Easy Replacement for 95% of Traditional Fixtures

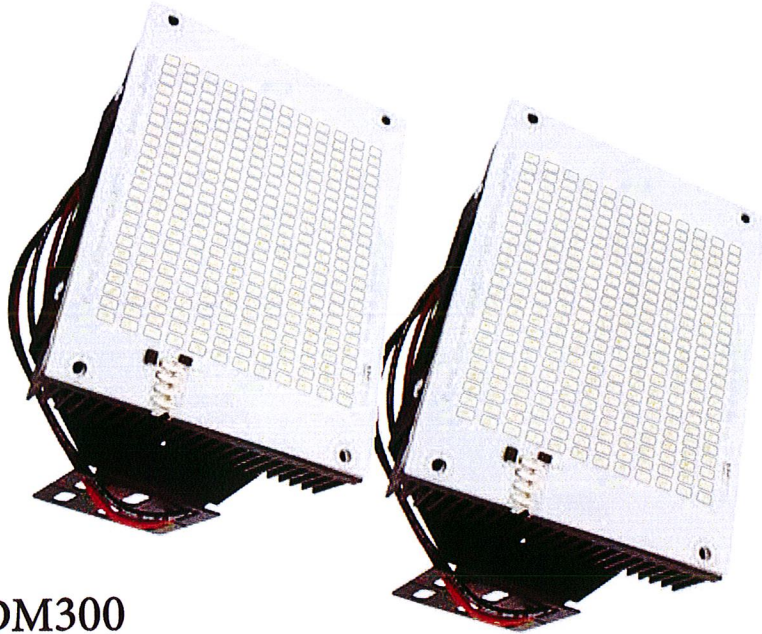

DM300

RECOMMENDED APPLICATION

- Parking Lot
- Floods
- Street Lights
- Wall Packs
- Canopies
- High/Low Bays

PRODUCT CERTIFICATIONS

- ETL (UL-1598-C)
- DLC QPL Product

PROTECTION AGAINST

- Short Circuit
- Over-current
- Over-voltage
- Over-temperature with auto-recovery

The unique design of the patent pending FlexMount™ System gives the High Efficacy Retrofit series the ability to easily retrofit a majority of fixtures whether it is a vertical or horizontal installation.

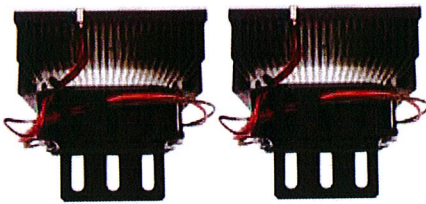

DM300 Back-Side

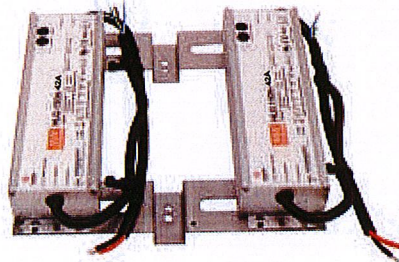

DM300 Dual Drivers

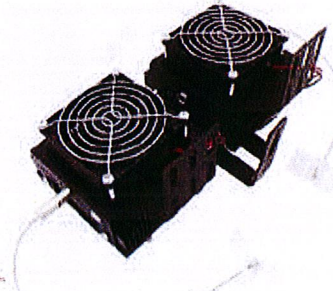

DM300 Back - Horizontal



DM300 Vertical FlexMount to Mogu

Product Specs

Input Amp Rating	120V - 1.255A 277V - 0.572A
AC Input Wattage	300W
# of LEDs	576
Lumens	45,600
Efficacy (Lumens/Watt)	157
CRI	80+
Voltage	120-277V
Dimensions (LxWxH)	Dual Drivers: 9.0"x2.7"x1.5" x 2 Dual Heads: 6.0"x10"x3" Plate : 13.5"x19.5" Plate extends from 19.75" to 26.5"
Weight	Dual Heads (cable): 4.8 lbs Total Shipping (cable): 8 lbs Dual Heads (plate): 7.6 lbs Total Shipping (plate): 10 lbs

Performance Specs

LED L70 Life Hours	>50,000 @ 55°C
Beam Angle	115°
Operating Temp	-40° to +50°C
Color Temp	5000K / 4000K / 3000K* (*Special order)

Additional Features

SUNON* Maglev Fan Technology	70,000+ hours operating life sustainable 24/7 operation
Mounting	Patent pending FlexMount™ mounting system or universal plates, to fit most/any HID fixture



DLC ID: PHOV4RD6
Very High Output Retrofit Kit
Retrofit Kits for Large Outdoor Pole/
Arm-Mounted Area and Roadway Luminaires



REPLACES
1000W HID

HiLumzUSA.com | sales@HiLumzUSA.com | O: 678.867.9200 | F: 404.537.1900

Copyright © HiLumz USA, 2015-2017. All Rights Reserved. Product and Company Names mentioned herein may be trademarks of their respective owners. Product enhancements may result in specification changes without notice. Specifications are deemed

DM300 HIGH EFFICACY RETROFIT

Easy Replacement for 95% of Traditional Fixtures



HILUMZ DIAMONZ 5 YEAR WARRANTY

5-year warranty on components, including the LEDs, fan, heat sink, etc. and same warranty on the LED Driver. See full warranty on website HiLumzUSA.com



30-DAY MONEY BACK SATISFACTION GUARANTEE

Limit of 2 Retrofit Kits per customer trial. Includes shipping costs.

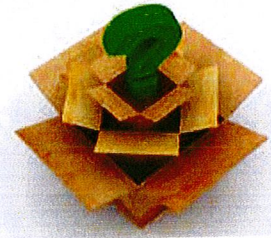

ORDERING INFORMATION

Build your SKU code by selecting the options in each column below. Use the number in bold as the numbers/characters to create the appropriate SKU code. See the following example.

ORDER SHEET

Order Example: HiLumz® Diamonz® DM300 - 5000K Temp - 80CRI - 277V - 120W Driver - Horizontal Mount

PRODUCT	CCT & CRI	DRIVER	MOUNTING
DM300 DM300 = DM300	5080 5080 = 5000K & 80CRI 4080 = 4000K & 80CRI 3080* = 3000K & 80CRI (*Special order)	1N 1N = 100-277V, 120W Driver 1D = 100-277V, 120W Dimmable Driver (0-10V) 347-480V Requires Step Down Transformer	H H = Horizontal Mount V = Vertical Mount FR = FlexTrim Plate Round FS = FlexTrim Plate Square

OTHER OPTIONS

SURGE PROTECTION

SP277
SP277 = Surge Protector - 20kA, 100-277V SP347 = Surge Protector - 20kA, 347V SP480 = Surge Protector - 20kA, 480V

PHOTO CELL SENSOR

PC120R
PC120 = Button Photo Cell 120V PC277 = Button Photo Cell 208-277V PC120R = Swivel Photo Cell 120V

LED Retrofit Proposal



Calwa Recreation and Park District

PROPOSAL BY:



TRUE NORTH LED

INSTALLATION BY:



Electrical Contractor, License #881252

TRUE NORTH LED | Tom Fernett | 661.205.2199
tom@truenorthled.com

Executive Summary

Calwa Recreation & Park District

October 13, 2019

Option 1, Primary Technology: LED, CA Based

Overall System Investment

Material Cost	Included
Labor Cost	Included
Recycling of Existing Fixtures in Accordance w/ CA Law	Included
Scissor and/or Boom Lift Rental	Included
System Design	Included
Project Management	Included
Rebate Administration and Acceptance as Payment*	Not Included
Surge Suppression	Not Included
Shipping	Included
Other Energy Conservations Measures (ECMs)	Not Included

Gross Investment	\$116,281
Less Rebate (Utility and/or Manufacturer)	\$0
Net Investment	\$116,281
Sales Tax (estimated)	\$7,728
Total	\$124,009



Profit from Upgrade

Annual Electrical Waste Reduction: Lighting & Controls	\$11,275
Annual Electrical Waste Reduction: HVAC, Source: R. Rundq	\$0
Annual Maintenance Savings	\$59
Rebate: Manufacturer/Instant (Expiration dates may apply, sub	\$0
Rebate: Utility Company (Subject to application and approval)	\$0

1st Year Profit from Upgrade **\$11,334**

Projected Annual Profit from Upgrade \$11,334
Average Monthly Profit from Upgrade \$944
Annual Kilowatt Hours Reduced 75,163
Demand Reduction, kW -

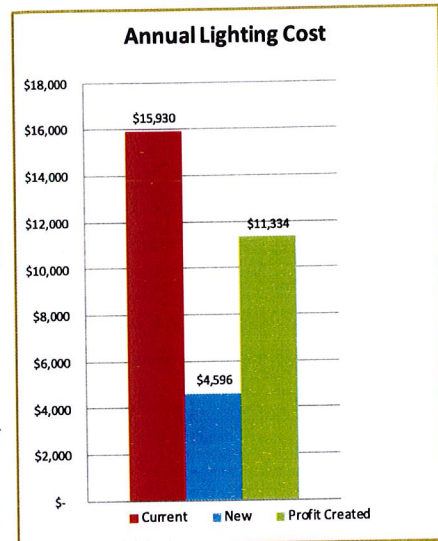

Financial Metrics

		Important Dates
Return On Investment (ROI)	10%	
Breakeven Period in Months	61.6	3/25/24
Payback Period in Months	123.1	5/25/29

10 Year Cash Flow

Year 1	(\$104,948)	Year 6	(\$48,280)
Year 2	(\$93,614)	Year 7	(\$36,946)
Year 3	(\$82,280)	Year 8	(\$25,613)
Year 4	(\$70,947)	Year 9	(\$14,279)
Year 5	(\$59,613)	Year 10	(\$2,946)

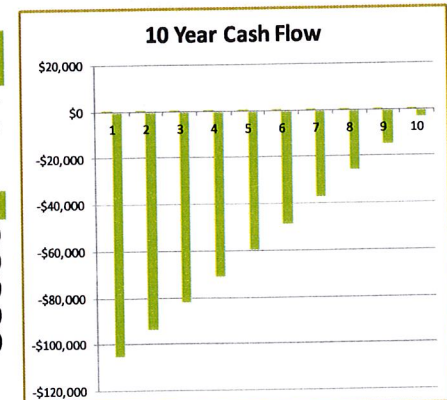

Lead Time: 4-5 Weeks or Less (Standard Products) Proposal Valid for 60 Days

OPTIONS (Check)

I Would Like to use Purchase Order #: _____
 I Would Like to Pay by Credit Card (check here) _____
 I Would Like a Free Cash Flow Agreement (check here) _____

Terms: 50% On Order, Balance on Completion

Accepted By (print): _____ Date: _____

Signature: _____

TF

PLEASE EMAIL ACCEPTANCE TO tom@truenorthled.com

Project Data by Facility Area

Calwa Recreation & Park District
Felix Ortiz

Option 1

0.15 per kWh Rate Used
Date: October 13, 2019

True North Rep: TF
Utility Co: PG&E

#	Facility Area Description	Voltage	EXISTING				New Fixture or Retrofit	PROPOSED					ENERGY SAVINGS					ANNUAL SAVINGS		
			Qty	Fixture	Watts	Annual Hours		Kelvin	Warr Years	Qty	Watts	Annual Hours	Existing Annual kWh	Lighting kWh Saved	Controls Savings	Controls kWh Saved	Total kWh Saved		kW (demand) Saved	
1	S Field	480	20	1000w MH	1080	912	New	Linmore Site Lighter 300w HV + Surge Sup	5000	10	20	300	912	19,699	14,227	0	0	14,227	15.60	\$ 2,134
2	NW Field	480	33	1000w MH	1080	912	New	Linmore Site Lighter 300w HV + Surge Sup	5000	10	33	300	912	32,504	23,475	0	0	23,475	25.74	\$ 3,521
3	NE Field	480	47	1000w MH	1080	912	New	Linmore Site Lighter 300w HV + Surge Sup	5000	10	47	300	912	46,293	33,434	0	0	33,434	36.66	\$ 5,015
4	SW Field	480	6	1000w MH	1080	912	New	Linmore Site Lighter 300w HV + Surge Sup	5000	10	6	300	912	5,910	4,268	0	0	4,268	4.68	\$ 840
5	Basketball	480	12	100w MH	128	912	New	Linmore Site Lighter 150w HV + Surge Sup	5000	10	12	150	912	1,401	-241	0	0	-241	-0.26	\$ (38)
							Totals:				118			105,807	75,163	0	0	75,163	82.42	\$ 11,275

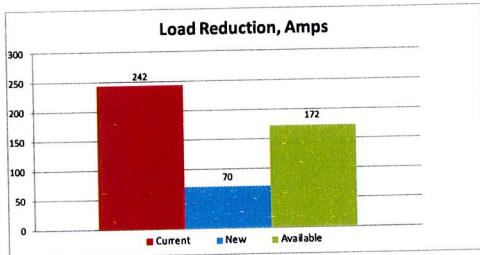

*Chart Data for Facility Areas on this Page Only

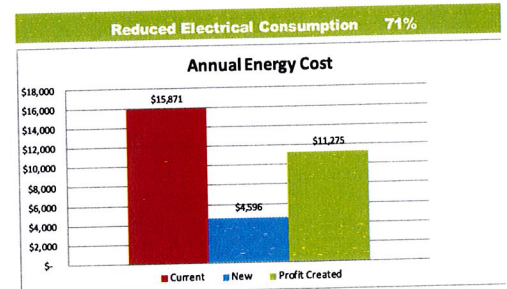

*Chart Data for Facility Areas on this Page Only

SITE LIGHTER (SL1)

Linmore LED Labs Site Lighter (SL1) is a superior combination of performance, value, and form factor. The body of the Site Lighter is unique in that it is extruded aluminum and exceptional at moving thermal energy while the rest of the market uses castings or weldments. Beyond the thermal efficiency of the housing, the aesthetics are modern and attractive. Efficacy averages 165 lumens/watt across our models putting the Site Lighter in rare space and bringing ultra-low wattages to site lighting. A variety of optic packages direct the light where it is needed. Built to last, the Site Lighter incorporates Linmore's drivers for years of sustainable ownership. When the objective is to maximize value in your exterior lighting with power, energy savings, and aesthetics, the Linmore Site Lighter is the clear choice.



HIGHLIGHTS

Optics:

Full Cut-Off
Type 2, Type 3, Type 4 & Type 5
Clear, Polycarbonate Lens
Glare Shields

Efficacy:

Ultra-High Efficacy-Up to 183 Lumens per Watt
Industry Leading

Construction:

Extruded Aluminum Body
Heavy Duty Powder Coating
Modern Form Factor

Controls/Sensors:

Linmore LED Driver 0-10V Dimming
Motion/Dimming Sensor
Photo Cell

Bracket Options:

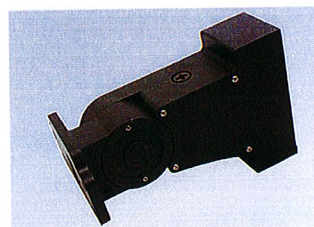

Rapid Mount Bracket
(Patent Pending)

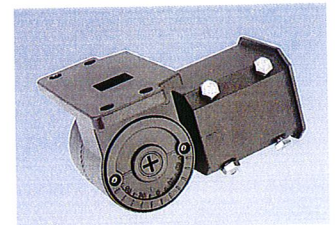

Slip Fitter
(Knuckle Adapter)

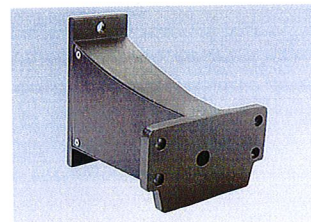

Straight Arm

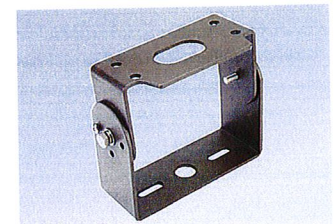

Trunnion (Yoke) Bracket

SITE LIGHTER (SL1)

Specifications

Suitability	Wet Locations-IP65 Rated
Warranty	10 Years
Expected Life	L70- 150,000 Hours
System Wattages	50W, 75W, 100W, 125W, 150W, 200W & 300W, 400W
Color Rendering Index (CRI)	>70
Color Temperature	2200K, 3500K, 4000K & 5000K

Operating Temperature	-40F to +130F
Efficacy	(5000K) Up to 183 Lumens/Watt
Voltage	120-277V, 200-480V
Certifications	UL 1598, FCC CFR 47, Part 15, ROHS, CUL Canada, BAA/TAA Compliant, ANSI C136.31-2010 "ANS for Roadway and Area Lighting Equipment - Luminaire Vibration"
Design Lights Consortium	Yes

Ordering Information

Model	Housing Size	Wattage	Kelvin	Optic	Volts	Housing Color	Mounting	Options
LL-SL1-	Small (SM)	50	2200K (22K)	Type 2 (T2)	120-277V (UNV)	Bronze (BRN)	Slip Fitter (SF)	FSP-201 (SN)
	Medium (MD)	75	3500K (35K)	Type 3 (T3)	200-480V (HV)	White (WHT)	Standard Arm (SA)	Photo Cell (PC)
	Large (LG)	100	4000K (40K)	Type 4 (T4)		Black (BLK)	Trunnion (TM)	
	Extra Large (XL)	125	5000K (50K)	Type 5 (T5)	Flood (60)	Custom (CUS)*	Slip Fitter/ Knuckle Adapter (SF)	
		150						
200								
	300							
	400							

* Special Order

Example

LL-SL1-SM-75WD-50K-T2-UNV-BRN-SF-SN

Lumen Packages

	T2	T3	T4	T5	60	Housing Type	Size (WxLxH)	Weight
50W	9897	9838	9611	9516	7000	Small	10.75 x 17 x 4 (taper to 1.5)	14
75W	13104	13026	12636	12558	10500	Small	10.75 x 17 x 4 (taper to 1.5)	14
100W	16224	16126	15600	16175	14000	Small	10.75 x 17 x 4 (taper to 1.5)	14
125W	21710	21493	20930	21645	17250	Medium	12.62 x 17 x 4 (taper to 1.5)	16
150W	25272	25019	24382	25196	20700	Medium	12.62 x 17 x 4 (taper to 1.5)	16
200W	30923	30745	32240	29648	26800	Medium	12.62 x 17 x 4 (taper to 1.5)	16
300W	47424	46950	45552	47282	40200	Large	20 x 17 x 4 (taper to 1.5)	24
400W	61000	61000	64000	59500	52000	Extra Large	22 x 17 x 4 (taper to 1.5)	37

BUG B5-U0-G5 B4-U0-G4 B3-U0-G3 B5-U0-G5 B3-U0-G1

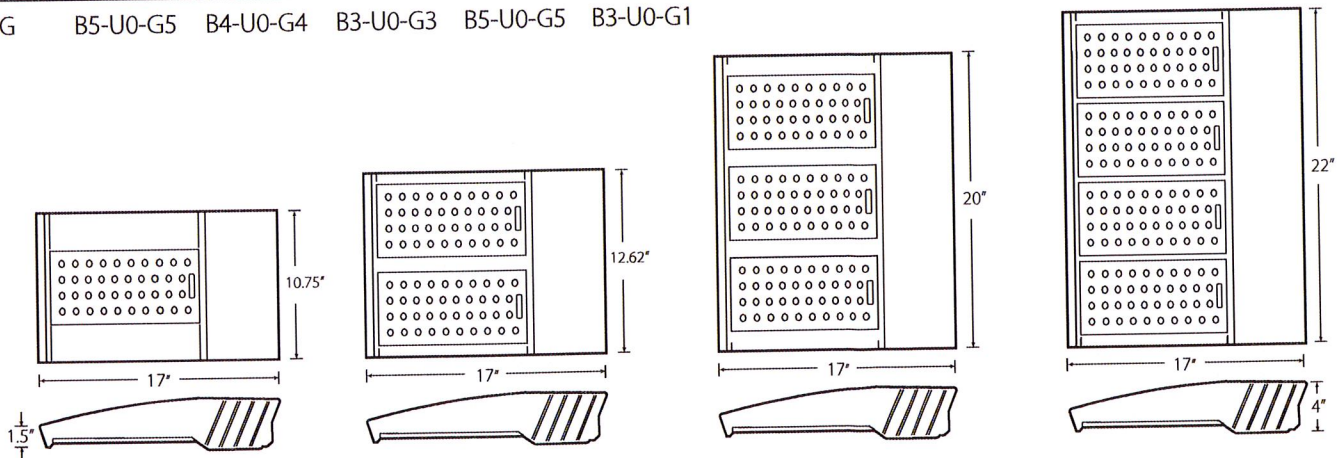

Specifications are Subject to Change.

SITE LIGHTER (SL1)

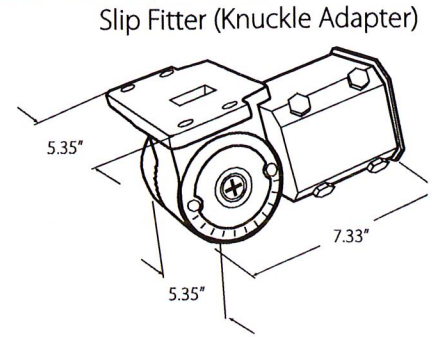
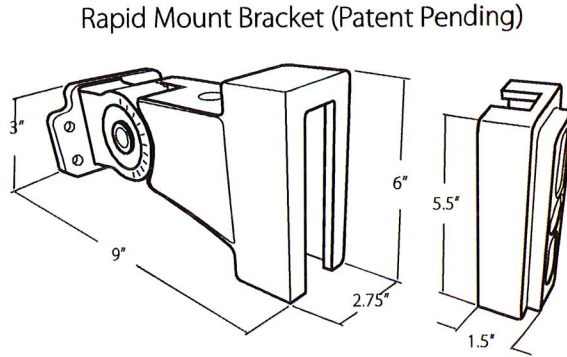
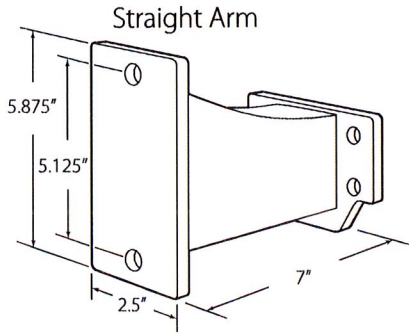

Glare Shield - Side

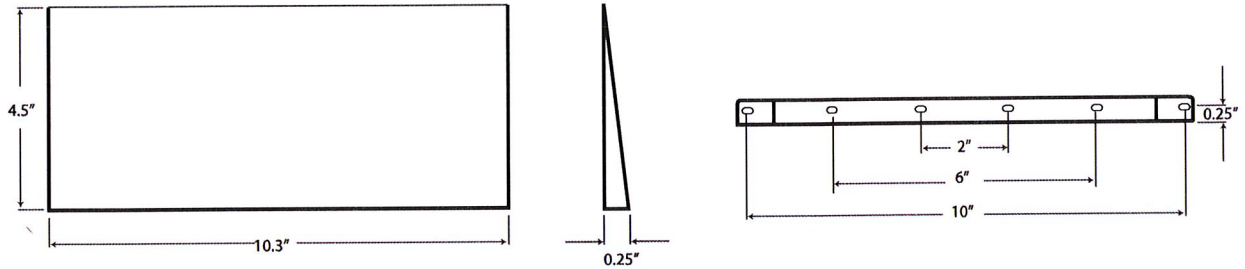

Glare Shield - Back

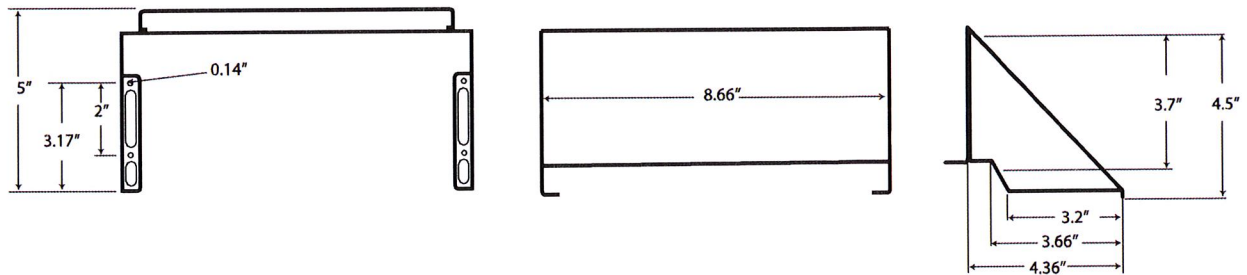

EPA Calculation

Wattage						
50W	0.61	0.88	1.22	1.24	1.24	0.46
75W	0.61	0.88	1.22	1.24	1.24	0.46
100W	0.61	0.88	1.22	1.24	1.24	0.46
125W	0.61	0.88	1.22	1.24	1.24	0.46
150W	0.61	0.88	1.22	1.24	1.24	0.46
200W	0.61	0.92	1.22	1.24	1.24	0.46
300W	0.61	0.97	1.22	1.24	1.24	0.46
400W	0.61	0.97	1.22	1.24	1.24	0.46

Specifications are Subject to Change.

SITE LIGHTER (SL1)

System Components

T2	Type 2 Optics
T3	Type 3 Optics
T4	Type 4 Optics
T5	Type 5 Optics
FR-L	Front Row Optics
FR-R	Front Row Optics
FL35	Flood Optics 35 Degrees
FL60	Flood Optics 60 Degrees
LL-SL1-SM-GSB	Site Lighter Glare Shield Back for use with Small Chassis (50-100w)
LL-SL1-MD-GSB	Site Lighter Glare Shield Back for use with Medium Chassis (125-200w)
LL-SL1-LG-GSB	Site Lighter Glare Shield Back for use with Large Chassis (300w)
LL-SL1-XL-GSB	Site Lighter Glare Shield Back for use with Extra Large Chassis (400w)
LL-SL2-ALL-GSS	Side Lighter Glare Shield Side for use with All Models, each
HV1	High Voltage Driver, 200-480 Volt, for SL1 Fixtures up to 200 Watts, adder
HV2	High Voltage Driver, 200-480 Volt, for SL1 Fixtures over 201 Watts, adder
SPD-277P-20KA-EC1	20ka Surge Suppressor
PC-UNV	Photocell, Button, Mounted in Side Plate, 120-277 Volt
PC-480V	Photocell, Twist Lock, 480 Volt
LL-SL1-RMB	Rapid Mount Bracket
LL-SL1-SA	Straight Arm Bracket
LL-SL1-SF	Slip Fitter Bracket
LL-SL1-TM	Trunion Mount Bracket
LL-SL1-A1	Vertical or Horizontal Mount for Flat Surfaces
LL-SL1-A2	Horizontal Mount for Round Poles
LL-SL1-A3	Horizontal Wall Mount
LL-SL1-A4	Vertical Wall Mount
LL-SL1-A10	Single Fixture Multi-Mount Bracket
LL-SL1-A12	Round to Square Pole Adapter
LL-SL1-A5	Square to Vertical Slip Fitter Adapter for 4" Square Pole
LL-SL1-A6	Square to Vertical Slip Fitter Adapter for 5" Square Pole
LL-SL1-A18	Square to Vertical Slip Fitter Adapter for 6" Square Pole
LL-SL1-A7	Round Pole to Slip Fitter Adapter for 4" Round Pole
LL-SL1-A14	Round Pole to Slip Fitter Adapter for 3" Round Pole
LL-SL1-A17	Slip Fitter Adapter for 4"-5" Square Poles
LL-SL1-A8	Two Fixture Bullhorn
LL-SL1-A9	Three Fixture Y Tenon
LL-SL1-A11	Three Fixture Straight Tenon
LL-SL1-A13	Four Fixture Straight Tenon
LL-SL1-A15	Three Fixture T Tenon
LL-SL1-A16	Two Fixture L Tenon

A detailed Exterior Application Guide can be found at linmoreled.com/pdfs/Exterior-Application-Guide.pdf

RECEIPT OF CONTRIBUTION AND RELEASE OF LIABILITY

Calwa Recreation and Park District ("District") hereby accepts a contribution from the County of Fresno ("County") in the amount of Five Thousand (\$5,000.00) dollars to be used for the renovation of the swimming pool in Calwa Park.

The District specifically acknowledges that the County has no responsibility or liability with respect to the contracting, renovation, construction or operation of the pool in Calwa Park. Further the District releases the County, and all its officers, employees, agents, contractors and successors from any and all liability from any damages, claims, lawsuit, loss, or injury resulting from the contracting, renovation, construction or operation of the pool in Calwa Park. This constitutes a general release of liability for all claims known and unknown and the District expressly waives the provisions of California Civil Code §1542 which provides:

"A general release does not extend to claims that the creditor or releasing party does not know or suspect to exist in his or her favor at the time of executing the release and that, if known by him or her, would have materially affected his or her settlement with the debtor or released party."

The District and the person executing this release on behalf of the District warrant that said person has the authority to act for and bind the District to the terms of this release.

CALWA RECREATION AND PARKS DISTRICT

By: _____

Title: _____

Date: _____

Approved as to Form:



Daniel C. Cederborg, Fresno County Counsel

**Calwa Recreation and Park District
Agenda Item Transmittal**

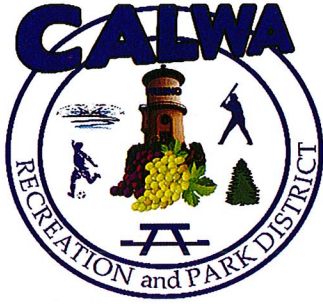

Meeting Date: November 19, 2019

Agenda Item Number: G-2

Wording for Agenda: Consider Potential Facilities Fees Increase and Direction to Staff .

Submitting: District Administrator

Contact Name and Phone Number: Felix Ortiz
559-264-6867

Department Recommendation: Direction to Staff on Potential New Resolution Approving Increased Fees for Use of District Facilities and Park.

Summary/Background:

After a year of review, staff felt that the fees being charged was not enough and would like to increase the fees. I would like suggestions from the Board.

Prior Board Actions:

Attachments: Resolution 2019-__ with Exhibit A

Recommended motion to be made by Board: Move Direction to Staff on Potential New Resolution Approving Increased Fees for Use of District Facilities and Park.

For action by:

District Board

Regular Session:

Consent Calendar

Regular Item

Public Hearing

Review:

**District Administrator
(Initials Required)**

**Calwa Recreation and Park District
Facilities Fees**

Administrative Fee	TBD
Key Deposit (Refundable)	\$50.00
Liability Insurance (required/unless furnished)	TBD
Security Guards (required with over 100 participants or if alcohol use)	TBD
Portable Restrooms	TBD
Waste Bin/Roll off	TBD
CALWA COMMUNITY HALL	
Cleaning Deposit (Refundable if no extra cleaning required by Calwa)	\$250.00
All Day Rental Fee w/Kitchen-includes tables & chairs	
Residents	400-600
Non-Residents	400-600
Rental Fee w/Kitchen-includes table & chairs	
Residents (Minimum 2-hour fee) / Each hour after 2 hr. requirement	100-200/75-150
Non-Residents (Minimum 2-hour fee) / Each hour after 2 hr. requirement	100-200/75-150
Resident Funeral Event	100-150
Non-Resident Funeral Event	100-150

EXCLUSIVE PARKS USE (Entire Park)	
Cleaning Deposit (Refundable if the park is left clean)	\$500.00
All Day Rental Fee (Non-Profit) Per Day	1000-2000
All Day Rental Fee Regular Organization	1500-2500
Art Wall	15-20 section
PARTIAL PARK RENTAL 1/4	
Cleaning Deposit (Refundable)	\$150.00
All Day Rental Fee (Non-Profit) Per Day	250-500
All Day Rental Fee Regular Organization	350-600
Will Need Contract Agreement	TBD

EXHIBIT A

PARK RENTAL: PICNIC AREA	
Rental Shelters (Areas)	35-50
Electricity (Additional Fee)	15-20
Bounce House Fee	15-30
SOFTBALL FIELDS	
Rental Softball Fields Per Game	25-50
Light Rental Use Per Hour	\$30.00
SOCCER FIELDS	
Adult Per Game / Lights Per Hour	\$50.00/\$30.00
Adult Non-Profit Per Game / Lights Per Hour	\$40.00/\$24.00
Youth Per Game/ Lights Per Hour	\$35.00/\$25.00
Youth Non-Profit Per Game / Lights Per Hour	\$30.00/\$20.00

current

MALAGA COUNTY WATER DISTRICT current.

PARK AND RECREATION FACILITIES: FEES, RENTALS, AND DEPOSITS

Rental Fees must be paid in advance and in full prior to use of the facility. Deposits are refundable only after inspection and approval by District Staff. Excess hours or cleanup and repair costs shall be withheld from the deposit.

<u>FACILITY</u>	<u>RATE</u>	<u>DEPOSIT</u>
1. Multi-Purpose Room	\$75/Hr (4 hour minimum) \$50/Hr set-up/cleaning (2 hour min/max per day) \$125/Hr after 8 hours and Holidays	\$ 400
2. Annex Room	\$25/Hr with #1, \$50/Hr alone (4 hour minimum) \$50/Hr set-up/clean-up (2 hours min/max per day) \$100/Hr after 8 hours and Holidays	\$200 \$100 w/#1
3. Kitchen	\$25/Hr with #1 or #2, \$50/Hr alone (4 hour minimum)	\$100
4. La Cantina	\$25/Hr with #1 or #2, \$50/Hr alone (4 hour minimum)	\$50
5. Meeting Room	\$25/Hr with #1 or #2, \$50/Hr alone (2 hour minimum)	\$50
6. Picnic Area and BBQ	\$25/Hr (4 hour minimum)	\$50
7. Unsheltered Picnic Area	\$25/Hr (4 hour minimum)	\$50
8. Gazebo	\$25/Hr (4 hour minimum)	\$50
9.		
10. Park Table #1	\$25 daily rate	\$25
11. Park Table #2	\$25 daily rate	\$25
12. Park Table #3	\$50 daily rate	\$50
13. Park Table #4 (Horseshoe)	\$50 daily rate	\$50
14. Park Table #5	\$50 daily rate	\$50
15. Park Table #6	(Picnic Area & BBQ)	\$50
16. Park Table #7	\$25 daily rate	\$25
17. Park Table #8	\$25 daily rate	\$25
18. Park Table #9	(Gazebo)	\$50
19. Park Table #10	\$25 daily rate	\$25
20. Playground Area	\$25/Hr (4 hour minimum)	\$50
21. Pool	\$50/Hr (2 hour minimum) *Lifeguards additional at cost	\$50
22. General Field Area And Baseball Fields (each)	\$25/Hr no lights \$40/Hr with lights (2 hour minimum)	\$25

**CITY OF FRESNO
MASTER FEE SCHEDULE**

PARKS, RECREATION, & COMMUNITY SERVICES DEPARTMENT

NEIGHBORHOOD CENTER, PARKS, AND PLAYGROUND FACILITIES

When determined appropriate by the Director, private or non-profit groups requesting to schedule a special event at the neighborhood center, park, or playground facilities may be required to provide security guards from a certified security agency, police officers from the Police Department or additional recreation leaders. The number of security guards, police officers, or recreation leaders required will be determined by the type of event and the estimated attendance. Also, the Director is authorized to waive the user fee for Special Events which are determined to be beneficial to the City of Fresno.

A processing fee of \$25 will be assessed for failure to notify the department of a cancellation within 48 hours of the event.

Community & Neighborhood Centers*		464
Public Purpose, Semi-public, non-profit organizations:		
Auditorium (per hour/2 hour minimum)	37.50	
Gymnasium (per hour/2 hour minimum)	37.50	
Meeting rooms (per hour/2 hour minimum)	25.00	
Kitchen and equipment (hour or fraction)	60.00	
Security/cleaning deposit (flat/80% refundable)	100.00 - 500.00	
Private groups and organizations, social:		
Auditorium (per hour/2 hour minimum)	75.00	
Gymnasium (per hour/2 hour minimum)	75.00	
Meeting rooms (per hour/2 hour minimum)	50.00	
Kitchen and equipment (hour or fraction)	60.00	
Security/cleaning deposit (flat/80% refundable)	100.00 - 500.00	
Recreation Staff / per hour	15.00	539
Picnic/Pavilion Area		Effective
1/2 day	25.00	1/1/2018
Full day	50.00	
EOC Neighborhood Centers		489
Gymnasium (per hour/2 hour minimum)	100.00	
Playfield		489
Lighted (per hour / 2 hour minimum)	35.00	
Standard Time -- after 5 pm		
Daylight Savings Time -- after 8 pm		
Unlighted facility (per hour / 2 hour minimum)	25.00	489
Security/Cleaning Deposit (per facility) - flat/80% refundable	100.00 - 500.00	

* Gymnasium rates do not apply to EOC Neighborhood Center
** Large organized events are by contract only

RESOLUTION NO. 2018-6

RESOLUTION OF THE BOARD OF DIRECTORS OF THE CALWA RECREATION AND PARK DISTRICT APPROVING FEES FOR USE OF DISTRICT FACILITIES AND PARK

WHEREAS, the Board of Directors has adopted reasonable fees for the use of District facilities and parks; and

WHEREAS, the Board of Directors has determined that the District facilities and park fees be amended to reflect the reasonable cost of providing the services and to allow for affordability; and

WHEREAS, after review and consideration, it is deemed by the Board of Directors that it is in the best interest of the District and its residents that certain fees be adjusted.

NOW, THEREFORE, the Board of Directors of the Calwa Recreation and Park District / resolves as follows:

Section 1. The foregoing recitals are true and correct and are incorporated by reference.

Section 2. The Board approves the Calwa District Facilities and Park Fees schedule attached as Exhibit A.

Section 3. District staff is directed to take all administrative actions necessary to implement the attached listing of effective District fees.

Section 4. This resolution shall be effective upon adoption.

CERTIFICATION

The foregoing Resolution No. 2018- 6 was adopted at a regular meeting on Oct. 16 2018, by the following vote:

AYES:

5

NOES:

0

ABSTENTIONS:

0

ABSENCES:

0

Secretary of the Board of Directors

**Calwa Recreation and Park District
Agenda Item Transmittal**

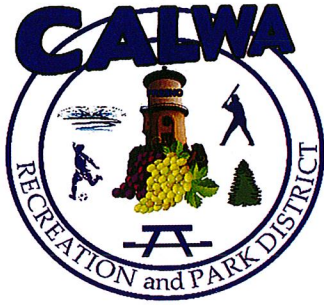

Meeting Date: November 19, 2019

Agenda Item Number: G-3

Wording for Agenda: Review and approve to allow District Administrator to sign Receipt of Contribution and Release of Liability form to receive, from the County of Fresno, Five Thousand (\$5,000.00) dollars to be used for the renovation of the swimming pool in Calwa Park.

Submitting: District Administrator

Contact Name and Phone Number: Felix Ortiz
559-264-6867

For action by:
 District Board

Regular Session:
 Consent Calendar
 Regular Item
 Public Hearing

Review:

**District Administrator
(Initials Required)**

Department Recommendation: Approve to allow District Administrator to sign Receipt of Contribution and Release of Liability form to receive, from the County of Fresno, Five Thousand (\$5,000.00) dollars to be used for the renovation of the swimming pool in Calwa Park.

Summary/Background: By signing this release of liability, it will allow Fresno County to release \$5,000 dollars donation check to go towards the Calwa Swimming Pool Project.

Prior Board Actions:

Attachments: Release of Liability Form

Recommended motion to be made by Board: Move to approve to allow District Administrator to sign Receipt of Contribution and Release of Liability form to receive, from the County of Fresno, Five Thousand (\$5,000.00) dollars to be used for the renovation of the swimming pool in Calwa Park.

RECEIPT OF CONTRIBUTION AND RELEASE OF LIABILITY

Calwa Recreation and Park District ("District") hereby accepts a contribution from the County of Fresno ("County") in the amount of Five Thousand (\$5,000.00) dollars to be used for the renovation of the swimming pool in Calwa Park.

The District specifically acknowledges that the County has no responsibility or liability with respect to the contracting, renovation, construction or operation of the pool in Calwa Park. Further the District releases the County, and all its officers, employees, agents, contractors and successors from any and all liability from any damages, claims, lawsuit, loss, or injury resulting from the contracting, renovation, construction or operation of the pool in Calwa Park. This constitutes a general release of liability for all claims known and unknown and the District expressly waives the provisions of California Civil Code §1542 which provides:

"A general release does not extend to claims that the creditor or releasing party does not know or suspect to exist in his or her favor at the time of executing the release and that, if known by him or her, would have materially affected his or her settlement with the debtor or released party."

The District and the person executing this release on behalf of the District warrant that said person has the authority to act for and bind the District to the terms of this release.

CALWA RECREATION AND PARKS DISTRICT

By: _____

Title: _____

Date: _____

Approved as to Form:



Daniel C. Cederborg, Fresno County Counsel



County of Fresno

COUNTY CLERK/REGISTRAR OF VOTERS
BRANDI L. ORTH

November 6, 2019

Felix Ortiz
District Administrator
Calwa Recreation and Park District
4545 E Church Ave
Fresno, CA 93725

Subject: Calwa Recreation and Park District

Dear Mr. Ortiz:

Your facility has been chosen to serve as a Fresno County Vote Center for the March 3, 2020 election as a 4-day Vote Center! We have gone through a rigorous and detailed process as we prepare to implement the Voter's Choice Act and have carefully selected 53 Vote Center locations throughout Fresno County.

We have examined every potential location and have analyzed the details of each location, considering 14 different criteria outlined in the California State Elections Code. It has been determined that your location is one of the best places in your area to host a Vote Center for Fresno County.

Thank you for your willingness to serve the public in this process. My staff will be working with you to gain access to your facility so that we can complete a required physical survey for accessibility, review parking options and plan for the physical layout. We will also be conducting electronic connectivity testing so that voting equipment can communicate effectively with our main office.

Page 2
Felix Ortiz
November 6, 2019

We have also enclosed a Vote Center Use Agreement. Please review, complete, and sign the document and return it to us in the enclosed envelope by November 27, 2019.

On behalf of Fresno County and its voters, we thank you for the role that you will play in providing voting opportunities with these exciting new changes. Our democracy depends on public participation and your agreement to serve as a Vote Center plays a critical role.

Please contact Cindy Lee at (559) 600-3038 should you have any questions or need further information.

Sincerely,



Brandi L. Orth
County Clerk/Registrar of Voters

Attachment



**FRESNO COUNTY
REGISTRAR OF VOTERS**

Brandi Orth, Registrar of Voters

**VOTE CENTER FACILITY
USE AGREEMENT**

Name of Facility: Calwa Recreation & Park District

Buildings/Rooms to be utilized: Hall

Parking Spaces: (see attached drawing with highlighted parking) _____

Facility Owner: _____

Facility Physical Address: 4545 E Church Ave

Facility Mailing Address: _____

Facility City/Zip: Fresno CA, 93725

Facility Primary Contact Name: _____

Facility Primary Contact Phone: _____

E-mail address: _____

Fax: _____

Emergency Contact Name: _____

Emergency Phone: _____

This Agreement ("Agreement") is entered into this ____ day of _____, 2019 between the County of Fresno-Fresno County Registrar of Voters ("County") and _____ ("Facility"), and provides County access to and usage of the above-named Facility and specified buildings/Rooms and Parking, upon the following terms and conditions:

March 3, 2020, Presidential Primary Election:

Four-Day Vote Center – open to the public

Voting Days: Saturday, February 29, 2020, every day through and including March 3, 2020

Voting hours from February 29, 2020 through and including Monday, March 2, 2020: 9:00 – 5:00 pm

Voting hours on election day, March 3, 2020: 7:00 am to 8:00 pm

1. Equipment and Supplies:

- Facility shall provide a secure storage area to store voting equipment and supplies including County access to this storage area, for up to three (3) days prior to the first Voting Day listed above, and during the Voting Days/Hours.
- The voting equipment and supplies shall be retrieved by County no later than (3) three days after the last Voting Day listed above.
- Delivery and pick-up of County's voting equipment and supplies shall occur during the Facility's business hours, which are _____.



FRESNO COUNTY REGISTRAR OF VOTERS

Brandi Orth, Registrar of Voters

VOTE CENTER FACILITY USE AGREEMENT

2. Facility Requirements During Voting Days/Hours

- Facility shall provide access to the Buildings/Rooms and Parking for County Vote Center Staff at least one (1) hour before, and up to one (1) hour after Voting Hours each day.
- Additional access for Accessibility Survey conducted by Fresno County Election Officials, and other visits in addition to the identified Voting Days/Hours to Facility may be required to test equipment or obtain additional information for Facility vote center layout and Facility shall cooperate with County's requests for such additional access.
- Air Conditioning/Heating shall be provided in good working order each day in the Buildings/Rooms.
- Facility shall provide adequate free parking for voters and County election staff.
- Facility shall provide sufficient interior and exterior lighting for Buildings/Rooms and Parking.
- Facility shall provide functioning electrical outlets in the Buildings/Rooms serving as designated voting area.
- Facility shall provide access to functioning restrooms for Election Staff
- Facility shall provide the appropriate and adequate space and Parking for County's use for voting purposes free of any other activities during the Voting Days/Hours.
- Facility shall make arrangements for facility to be unlocked and locked at the agreed upon time for County Vote Center Staff to access the Facility.
- The path of travel on the Facility's property, including within the line of sight from the path of travel, to and from the Buildings/Rooms and Parking shall be free from signage, displays, audible dissemination of information and obstructions interfering with the neutrality or operations of the Facility with respect to election/voting purposes, whether or not within 100 feet of a polling place, a vote center, an elections official's office, or a satellite location.

3. Hold Harmless/Indemnification

County shall indemnify, defend, save, and hold harmless the Facility, its officers, agents, and employees, from and against any loss, damage, liability, cost, or expense arising out of the designation and utilization of the Facility as a Vote Center, except to the extent such claims arise through the negligent act or omission of the Facility, its officers, agents, and employees.

Nothing in this provision shall be construed to create any duty to, any standard of care with reference to, or any liability or obligation, contractual or otherwise, to any third party. The provisions of this indemnity obligation shall survive the expiration or termination of this Agreement.

This indemnification shall not be constructed so as to relieve any insurer of its obligation to pay any insurance proceeds in accordance with the terms and conditions of valid and collectible insurance policies. This indemnification is secondary to any available primary insurance or coverage.

4. Certificate of Self-Insurance

Fresno County will provide a certificate of Self-Insurance.



**FRESNO COUNTY
REGISTRAR OF VOTERS**

Brandi Orth, Registrar of Voters

**VOTE CENTER FACILITY
USE AGREEMENT**

5. Additional Information

Facility shall not unilaterally cancel or terminate this Agreement. Facility shall not change or relocate the agreed upon Buildings/Rooms outside of an event of a natural disaster or unforeseen building structural damage. County may terminate this Agreement at any time and for any reason, and not use the Facility.

6. Terms and Conditions

No alteration or variation of the terms of this Agreement shall be valid, unless made in writing and signed by the parties, and no oral understanding or agreement not incorporated herein shall be binding on either of the parties.

Facility acknowledges that its Buildings/Rooms, Parking and the pathway(s) to and from said Buildings/Rooms and Parking will be used for the public purpose of voting in an election(s) and as such Facility agrees to comply with all federal, state and local laws governing said election(s).

7. Governing Law

Venue for any action arising out of or relating to this Agreement shall be in Fresno County, California. This Agreement shall be governed by the laws of the State of California.

8. Authority

Facility represents and warrants that the individual executing this Agreement on behalf of the Facility is duly authorized to execute and deliver this Agreement, and that this Agreement is binding upon the Facility in accordance with its terms.

9. Entire Agreement

This Agreement constitutes the entire agreement between the County of Fresno and Facility with respect to the subject matter hereof, and supersedes all prior agreements, whether oral or written, negotiations, proposals, commitments, writings, advertisements, publications, and understandings of any nature whatsoever, unless expressly referenced in this Agreement.



**FRESNO COUNTY
REGISTRAR OF VOTERS**

Brandi Orth, Registrar of Voters

**VOTE CENTER FACILITY
USE AGREEMENT**

IN WITNESS WHEREOF, the parties hereto have executed this Agreement as of the day and year first hereinabove written.

Facility Owner/Agent:
Calwa Recreation & Park District

COUNTY:
COUNTY OF FRESNO

By _____
Name and Title

By _____
Robert W. Bash, Director of Internal
Services/Chief Information Officer

Address: _____

Date _____

RECOMMENDED FOR APPROVAL:
Brandi L. Orth, County Clerk/Registrar of Voters

By _____

RECOMMENDED FOR APPROVAL:
Daniel C. Cederborg, County Counsel

By _____
Deputy

FOR ACCOUNTING USE ONLY:
Fund: 0001
Subs: 10000
Org No. 2850
Acct. No. 7295

RECOMMENDED FOR APPROVAL:
Oscar J. Garcia, CPA, Auditor-Controller/
Treasurer-Tax Collector

By _____
Deputy